

Ultraflow Filter Housing Conversion Kit

GB

Operating instructions Converting instructions

To be kept in the vehicle!

Page 2
Page 10



Ultraflow Filter Housing Conversion Kit

Table of Content

Symbols used.....	3
Introduction.....	3
Operating instructions.....	4
Routine maintenance.....	4
Notes.....	5
Sterilising.....	5
How to prepare your water system for winter use.....	6
Accessories.....	6
Manufacturer's Warranty (European Union).....	8
Converting instructions.....	10
Intended use.....	10
Conversion of the water pump connection.....	10
Replacing the housing.....	11
Fixing the Ultraflow Filter Housing.....	11
Water connections.....	12
Electrical connection.....	12
Fixing to the caravan wall.....	14
Checking the installation.....	14

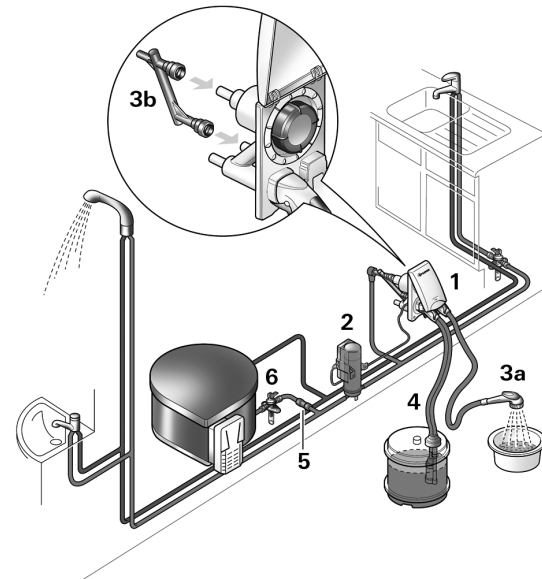

- 1 Filter Housing
- 2 Smart Switch
- 3a Shower assembly
- 3b Shower connection
- 4 Pump assembly
- 5 Non-return valve (see accessories)
- 6 Ultrastore drain valve

Symbols used



Symbol indicates a possible hazard.



Comment including information and tips.

Introduction

The Truma Ultraflow Filter Housing (1) is part of an unique, high quality product range designed to bring water to your caravan in a convenient and efficient manner.

The system includes a special filter which removes unpleasant tastes, smells and suspended particles to give clear, fresh tasting water.

The activated carbon, which removes chlorine, tastes and smells, etc. by adsorption and by mechanical filtration reduces algae and particles. The silver content avoids bacteriological growth in the filter.

Truma Ultraflow operates in the caravan water supply as a **pressurised system**. The optional available **Ultraflow Smart Switch** turns the water pump on and off regardless of the current atmospheric pressure and battery power (between 10 V and 14 V).



To prevent an excessive high pressure in the system, the use of a non-return valve (spring weighed – see accessories) in front of the water heater is essential.

The non-return valve (5) must be fitted between the drain valve and the first “T” connection. This also prevents the back flow of hot water to the cold water taps.

Please note the correct flow direction of the valve. No further non-return valves or other parts that can reduce the water flow may be used. Additional Truma drain valves do not reduce the water flow.

Also available, is a special outdoor shower (3a) which connects directly beside the pump. **Please note:** the Ultraflow Outdoor Shower has no electrical connections and works only in a pressurised system.

The Ultraflow Water Pump Assembly and Ultraflow Outdoor Shower are detachable from the Ultraflow Filter Housing for security and while touring. A blanking plug is available to blank off the inlets when the pump or shower is not attached.

To connect the pump, simply align the plug with the socket and push it into position. This makes both water and electric connections.

The shower plug contains no electrical connections.

To remove, pull the lower trigger and pull the plug from the socket.

Operating instructions



Please ensure that the lid is properly closed before driving!

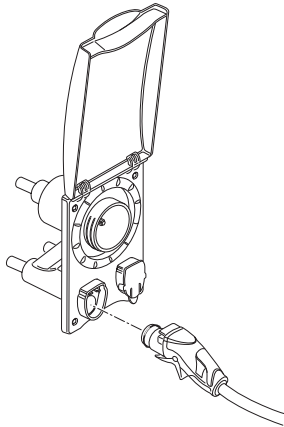

Raise the lid, clean both the water socket and the plug of the pump assembly.

Plug the pump assembly into the socket.

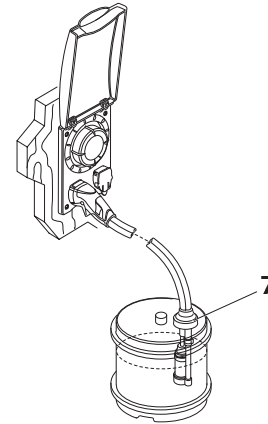

Place the pump into the water container, ensuring that it is fully submerged before operating the system. The dust cover (7) is to stop contaminants falling into the water container.

To remove the pump assembly from the Ultraflow Filter Housing, pull the lower trigger and pull out the hose plug.



Do not remove by pulling the hose or electric cable.

Routine maintenance

- Ensure that the O-ring seal on the hose plug and socket are free from dirt.
- To aid fitting of the plug assembly smear the O-ring with vegetable oil.
- To change the filter, turn the filter cap anti-clockwise and pull out the filter.

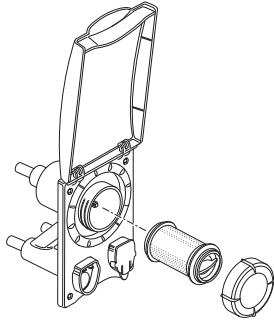

- After installation, please drain off the first litres until the filtrate is clear.

Maximum filtering efficiency (cleaning effect) can only be achieved if the filter is changed at regular intervals. The filter must be changed within 35 days of initial use, even if it was not in use during this time. Please remember that water is a foodstuff. We recommend that filtered water is consumed within 1 – 2 days and advise you to drain the system after long periods of disuse.

Use dial on the filter housing for guidance to replace after approx. 35 days of use.

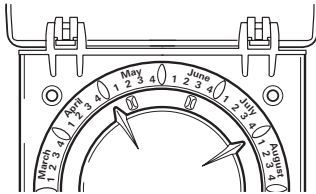

Notes

- Never allow the pump to run **dry**. Always ensure that the pump is submerged in the water or the lifetime of the pump will be reduced.
- **Before winter storage** the water system must be completely drained and the filter cartridge removed. Also recharge the pump assembly or the blanking plug. If you use the Ultraflow Outdoor Shower (optional) and have therefore installed the “connector”, please drain the filter housing by connecting up the Ultraflow Outdoor Shower and allowing the remaining water to drain via the open shower head. The filter hole may be sealed with the filter cap.
- **Clean the water system at the start and end of the season with sterilising fluid (see notes under sterilising).**

Sterilising

- **When cleaning the water system at the start or the end of the season it is advisable to use a sterilising fluid e.g. Chempro SDP or similar. It is recommended that for this operation the filter is removed as the fluid reduces the effectiveness of a new filter.**
- Flush the system thoroughly to remove the effective fluid traces.
- After sterilising the system at the start of the season it is recommended that a new Ultraflow filter cartridge should be fitted.

How to prepare your water system for winter use

During winter caravanning it is recommended to keep the water container within the caravan to prevent freezing.

This can be achieved by fitting an Ultraflow Compact Housing unit inside the caravan in a location where it is convenient to store a container, e.g. the washroom or under the sink etc.

Special instructions are supplied with the Ultraflow winter kit.

During the winter when the caravan or motor home is not in use, it is advisable to remove the filter to avoid any retained water within the filter freezing.

Winter Conversion Kit (white) part no.: 46060-01

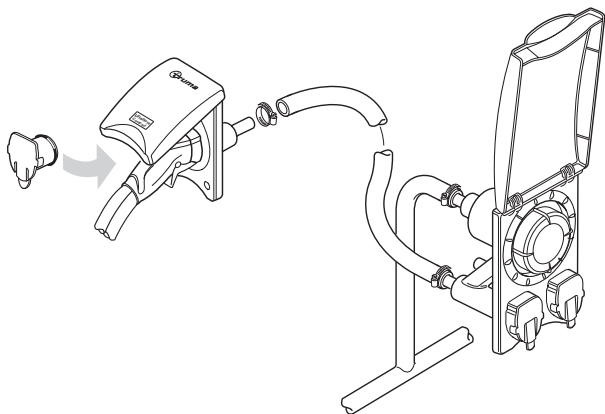

The blanking plug must be fitted to blank off the unused Compact or Filter system.

Accessories

Ultraflow Water Pump Assembly

The Water Pump Assembly comes complete with the water pump, container cover and storage clip. The submersible pump needs no priming and is extremely quiet in operation. This pump can be used with both the Ultraflow Filter Housing and the Ultraflow Compact Housing.

Standard pump assembly (hose length 800 mm)
part no.: 46040-01

Special version for motor caravans (hose length 1000 mm)
part no.: 46040-10

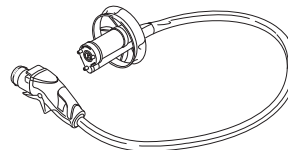

Non-return valves

Flexible hoses

part no.: 40060-90000

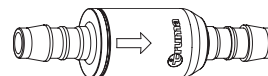

Semi-rigid-piping (John Guest System)

part no.: 40060-88000



Ultraflow Outdoor Shower

The outdoor shower connects directly to the Ultraflow Filter Housing beside the pump socket. The supplied connector with quick fittings ensures an easy installation.

Please note, that the shower has no electrical connections and works only in a pressurised system.

part no.: 46080-01

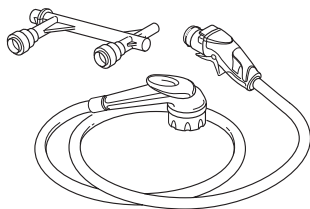

Ultraflow Waterline

The Ultraflow Waterline is a 15 metre "food quality" hose pipe. It comes complete with fittings and a special pressure reducing adaptor which allows caravanners to connect their Ultraflow caravan water system direct to a mains water supply without modification.

part no.: 46091-01

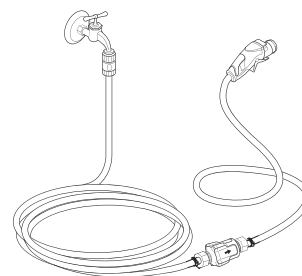

Ultraflow Replacement Filter

The Ultraflow Filter Cartridge is a high quality water filter which removes unpleasant tastes and odours from the caravan's stored water. For the occasional caravanner, the cartridge should be replaced at the start of each season. For the regular caravanner we recommend to replace the filter after 35 days of use.

part no.: 46020-01



Ultraflow Smart Switch

The self-calibrating Ultraflow Smart Switch has been designed to switch the pressure controlled submersible Ultraflow Maxi Pump fitted in caravans, motor homes and other vehicles.

part no.: 46120-51



Manufacturer's Warranty (European Union)

1. Scope of Manufacturer's Warranty

As the Manufacturer of the unit, Truma undertakes a warranty towards the Consumer that covers any material and/or manufacturing defects of the unit.

This Warranty is applicable in EU member states as well as in Iceland, Norway, Switzerland and Turkey. A Consumer is the natural person who was the first one to purchase the unit from the Manufacturer, OEM or dealer and who neither resold the unit in a commercial or self-employed professional capacity nor did he or she install it for a third party in such a capacity.

The Manufacturer's Warranty covers any of the aforementioned defects that occur within 24 months upon concluding the purchase agreement between the seller and the Consumer. The Manufacturer or an authorised service partner undertakes to remedy such defects through subsequent fulfilment, i.e. at its discretion either by repairing or replacing the defective item. Any defective parts shall become the property of the Manufacturer or the authorised service partner. If the unit is no longer manufactured at the time of defect notification and if replacement delivery has been opted for, then the Manufacturer may deliver a similar product.

If the Manufacturer remedies a defect under its warranty commitment, the term of the Warranty shall not recommence anew with regard to the repaired or replaced parts; rather, the original warranty period shall continue to be applicable to the unit. Only the Manufacturer itself and an authorised service partner shall be entitled to conduct a warranty job. Any costs that occur in the event of a warranty claim shall be settled directly between the authorised service partner and the Manufacturer.

The Warranty does not cover additional costs arising from complicated removal or installation jobs on the unit (e.g. dismantling of furnishings or parts of the vehicle body), and neither does it cover travel expenses incurred by the authorised service partner or the Manufacturer.

No further-reaching claims shall be permitted, especially damage claims presented by the Consumer or third parties. This provision shall not affect the validity of the German Product Liability Act (Produkthaftungsgesetz).

Neither does the voluntary Manufacturer's Warranty affects the Consumer's legally applicable claims for defects towards the seller in the relevant country of purchase. In individual countries there may be warranties that can be issued by the relevant dealer (official distributor, Truma Partner). In such cases the warranty can be implemented directly through the dealer from whom the Consumer bought the unit. The warranty regulations of the country in which the unit was purchased by the Consumer for the first time shall also be applicable.

2. Warranty exclusions

No warranty claim shall be applicable under the following circumstances:

- Improper use, contrary to the specified use
- Improper installation, assembly or commissioning, contrary to operating or installation instructions
- Improper operation, contrary to operating or installation instructions, particularly maintenance, care and warning notes
- Instances where repairs, installations or any other procedures have been conducted by non-authorised partners
- Consumable materials and parts which are subject to natural wear and tear
- Installation of replacement, supplementary or accessory parts that are not original Manufacturer's parts and which have thus caused a defect

- Damage arising from foreign substances (e.g. oils, plasticisers in the gas), chemical or electrochemical influences in the water, or cases when the unit has come into contact with unsuitable substances (e.g. chemical products, unsuitable cleaning agents)
- Damage caused by abnormal environmental or unsuitable operating conditions
- Damage caused by force majeure or natural disasters or any other influences not within Truma's responsibility
- Damage resulting from improper transport

3. Making a warranty claim

The warranty must be claimed with an authorised service partner or at the Truma Service Centre. All the relevant addresses and phone numbers can be found at www.truma.com, in the "Service" section.

To ensure a smooth procedure, we should be grateful if you could have the following details ready before contacting us:

- Detailed description of the defect
- Serial number of the unit
- Date of purchase

The authorised service partner or the Truma Service Centre will then specify the further procedure. To avoid transport damage, the affected unit must only be shipped upon prior arrangement with the authorised service partner or the Truma Service Centre.

If the warranty claim is recognised by the Manufacturer, then the transport expenses shall be borne by the same. If no warranty claim is applicable, the Consumer will be notified accordingly and any repair and transport expenses shall then be the Consumer's liability. We must ask you not to send in a unit without prior arrangement.

Converting instructions

Intended use

You need the replacement set to replace the Crystal System (Filter Housing) with the Ultraflow System (Filter Housing).

Conversion of the water pump connection

Open the hose clip e.g. with a screwdriver.

Remove the handle cap after pressing in both latches.

Unscrew the screw-type terminals of the plus / minus wires and pull out the cable.

Remove the connection piece and the hose clip.

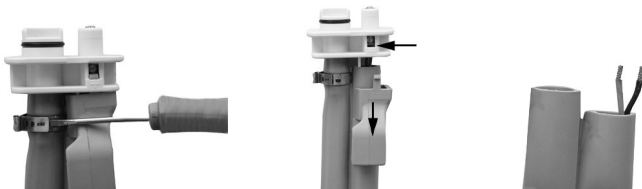

Cut off the wire end sleeves and crimp the enclosed spade connector (4.8 mm) to the plus wire and the spade connector (6.3 mm) to the minus wire.

Push the new hose clip over the water hose.



Push the water hose onto the lower part of the pistol handle and secure **tightly** with the hose clip.

Insert the plus / minus wire to the contacts in the pistol handle (observe the polarity).



Place the upper part of the handle (pistol handle) onto the lower part of the handle.



Replacing the housing

Interrupt the power supply to the water pump by disconnecting the battery.

Dismantle the Crystal Filter Housing.

To do this, unscrew the 4 screws, pull out the housing as far as necessary to allow the water hose and the plus and minus lines to be disconnected.

Unscrew the terminal screws for both lines + (brown or red) and - (blue or black) and pull out the cable.



The internal wiring of the caravan can be green "+" and white "-".

Loosen the hose clip of the water hose and remove the hose.

Place housing to the side.

Insert the Ultraflow Filter Housing so that the 4 old holes are located within the sealing surface, then mark the new attachment holes. Remove the housing and pre-drill the 4 holes with 2 mm.

Crimp the enclosed 4.8 mm spade connector to the end of the plus line cable (brown or red) and the 6.3 mm spade connector to the minus line (blue or black).

Fixing the Ultraflow Filter Housing

It is easier to bring the water hose and electric cable through the cut out and make any connection before fitting the Ultraflow Filter Housing to the caravan wall.

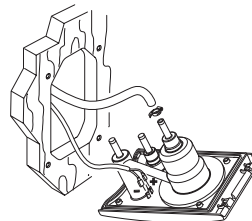

Water connections

The Ultraflow Filter Housing is designed for connection to 12 mm diameter bore flexible hoses or 12 mm diameter semi-rigid piping (e.g. John Guest fittings). Flexible hoses must be secured with suitable hose clips.

i Food quality hose must be used to avoid the risk of unpleasant tastes in the water.

At the rear of the Ultraflow Filter Housing there are three water connections, two are blanked off.

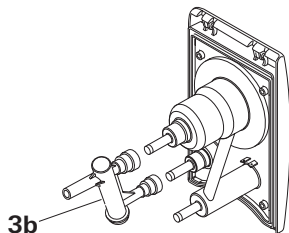

When the Ultraflow Filter Housing is to be used in conjunction with a Ultraflow Winter Kit (option – see page 5). Before connecting the blanked off end must be cut off.

Outdoor shower connection (3b). With the outdoor shower (option – see page 7) Truma supplies a connection pipe. Before use the blanked off end must be cut off.

Electrical connection

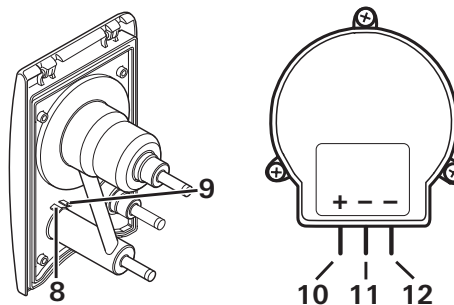

Ultraflow Filter Housing

- 8 Pump + = 4.8 mm spade connector
- 9 Pump - = 6.3 mm spade connector

Ultraflow Smart Switch

- 10 Battery + = 6.3 mm spade connector
- 11 Pump - = 6.3 mm spade connector
- 12 Battery - = 6.3 mm spade connector



The power supply must be rated with 6.3 AT (slow).

Power packs and power supply units must have a stabilised 12 V-output (ripple content less than 0.5 V). The use of an unfiltered power supply will cause an increased wear of the pump motor.

Ensure that the polarity is correct i.e. brown or red wire to „+“ and blue or black to „-“. The polarity is marked on the rear of the Ultraflow Filter Housing and on top of the Ultraflow Smart Switch.

The CSA (Cross Sectional Area) of the wire should be 0.75 mm².

Connect the Truma Smart Switch (10, 12) and the Ultraflow Filter Housing (8) to the filtered caravan 12 V supply (max. 0.5 V AC).

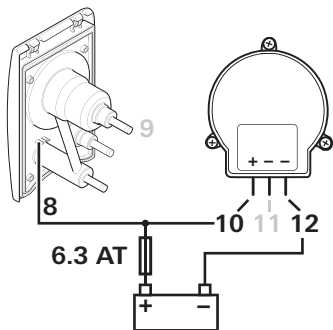

The Ultraflow Filter Housing (9) connects directly to the Truma Smart Switch (11).

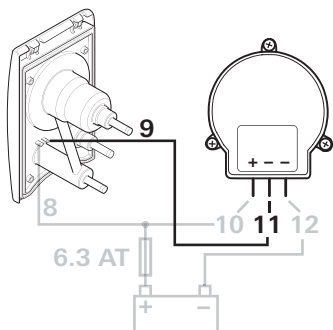

For the winter use, both housings must be connected directly to the Truma Smart Switch.

Important notes:

The use of isolated cable terminals is mandatory to avoid the risk of short circuits. For the same reason push the cable shoe connections/terminals completely over the connector.

If the polarity is reversed the pump will still operate but with a reduced performance.

In case of unintended reverse polarity the switch will probably not work correctly but due to the integrated protection it will not be destroyed.

The pump may be operated via switched taps or a pressure switch, a non-return valve is fitted as part of the Ultraflow Filter Housing.

If a pressure switch is to be used, then an electrical isolation main switch must be used in conjunction with it. The main switch should be positioned so that it is convenient for the user to operate.

See also the installation instructions supplied with the Truma Smart Switch.

Fixing to the caravan wall

After ensuring that both the electric and water connections are satisfactory, offer the Ultraflow Filter Housing into its position.

Apply a non hardening mastic (do not use silicone) sealant to the back flange of the Ultraflow Filter Housing and using the 4 countersunk head screws secure the Ultraflow Filter Housing into position.

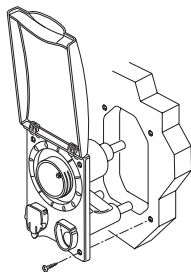

Finally remove any excess sealant from the coachwork.

Checking the installation



Before checking the installation, ensure that the rest of the water system is connected and that all the joints are secure.

As the supplied filter is new it is suggested to check the installation without filter.

A used filter is suggested to be replaced approx. 35 days after the first contact with water!

Clean the water socket and plug of the pump assembly (as both components will be dry and new it is suggested that a smear of vegetable oil on both surfaces will aid fitting). Push the two components fully together.

Place the pump into the water container and ensure that it is totally submerged. Check that the electric supply is connected and working satisfactory. Operate the system, and check that the water is flowing from all taps and that the system is free from leaks.

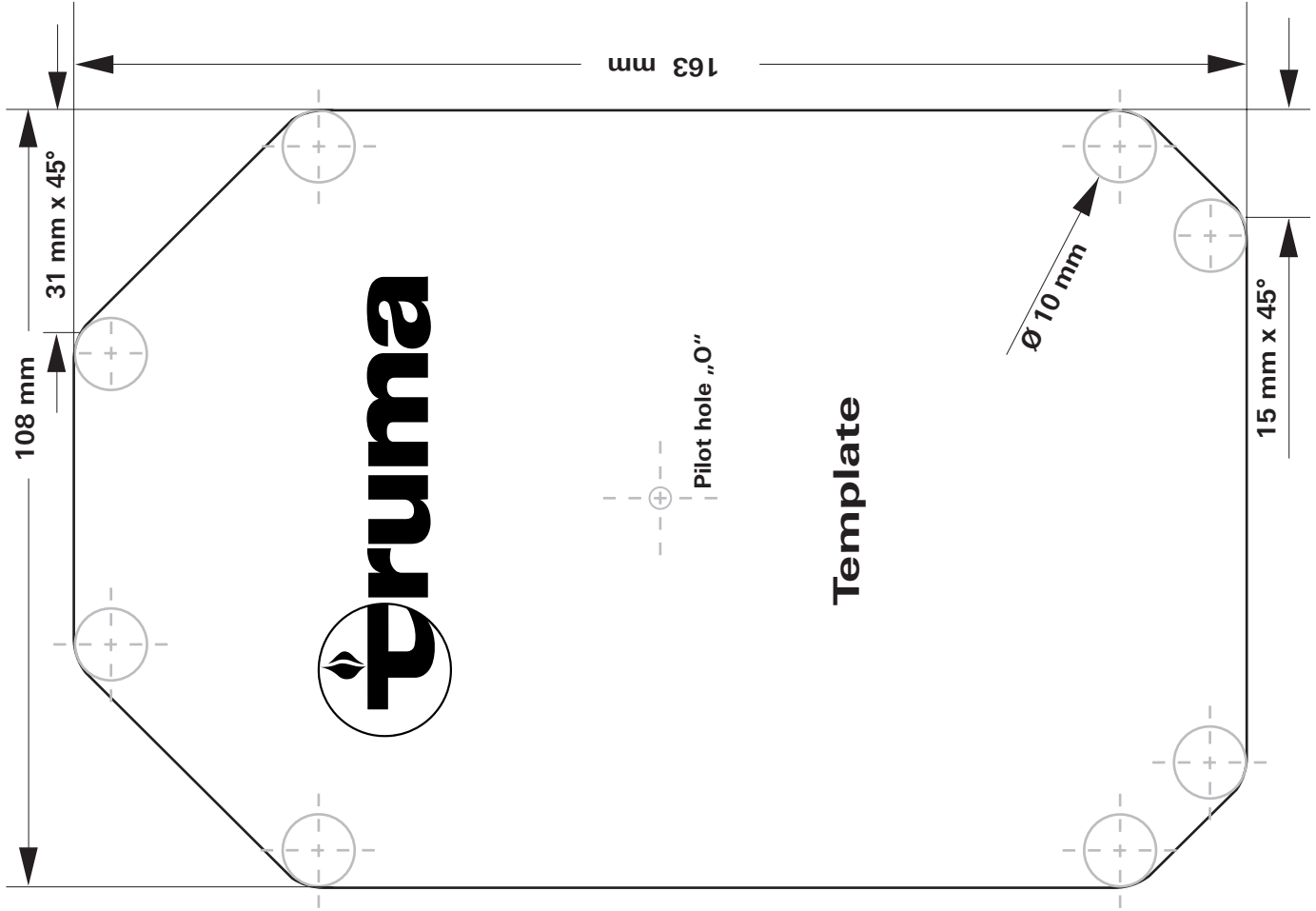

GB Always notify the Truma Service Centre or one of our authorised service partners if problems are encountered (see Truma Service book or www.truma.com).

Having the equipment model and the serial number ready (see type plate) will speed up processing.

Sales and Service in UK and Eire:
Truma (UK) Limited
2000 Park Lane, Dove Valley Park
Foston
South Derbyshire DE65 5BG

Service

Telephone: (0 12 83) 58 60 20
Telefax: (0 12 83) 58 60 29

sales@trumauk.com
www.trumauk.com