

# WAECO

mobile solutions



# Tropicool

## TC-14FL-AC, TC-21FL-AC, TC-35FL-AC

**D 4 Thermoelektrische Kühlbox**  
Bedienungsanleitung

**GB 13 Thermoelectric coolbox**  
Instruction Manual

**F 22 Glacière thermoélectrique**  
Notice d'emploi

**E 32 Nevera termoelectrica**  
Instrucciones de uso

**I 42 Frigorifero termoelettrico**  
Istruzioni per l'uso

**NL 51 Thermo-elektrische koelbox**  
Gebruiksaanwijzingen

**DK 60 Termoelektrisk køleboks**  
Betjeningsanvisning

**N 69 Termoelektrisk kjøleboks**  
Bruksanvisning

**S 78 Termoelektrisk kylbox**  
Bruksanvisning

**FIN 87 Sähkökäyttöinen kylmälauku**  
Käyttöohjeet

1

### TC-14FL-AC

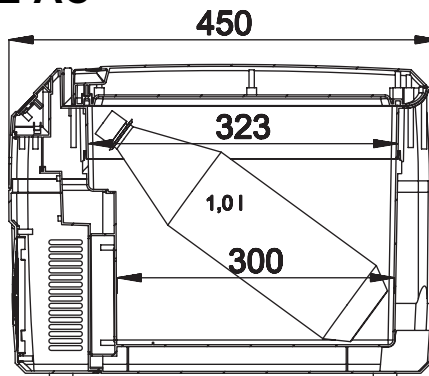
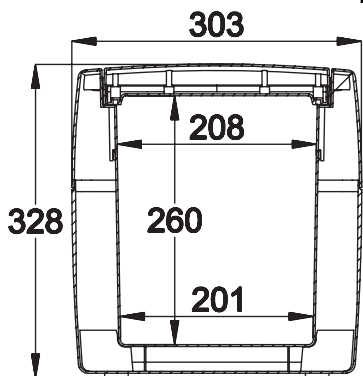

### TC-21FL-AC

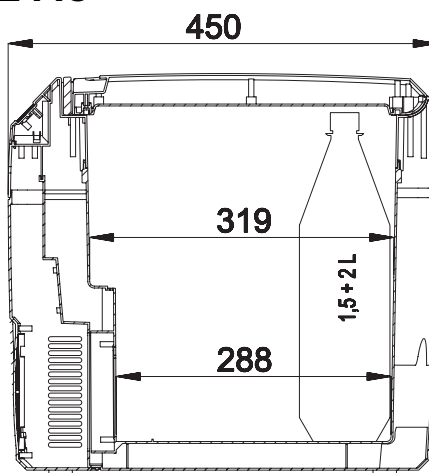
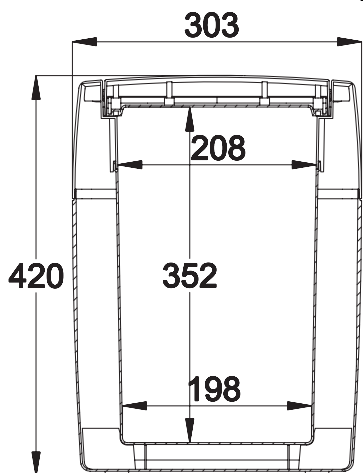

### TC-35FL-AC

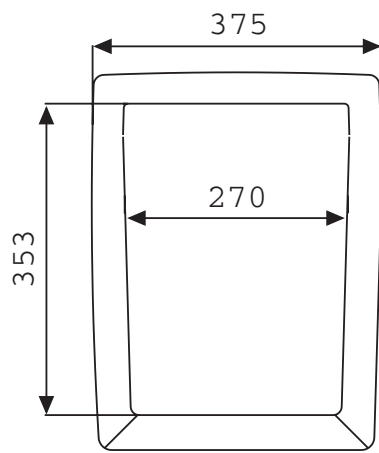
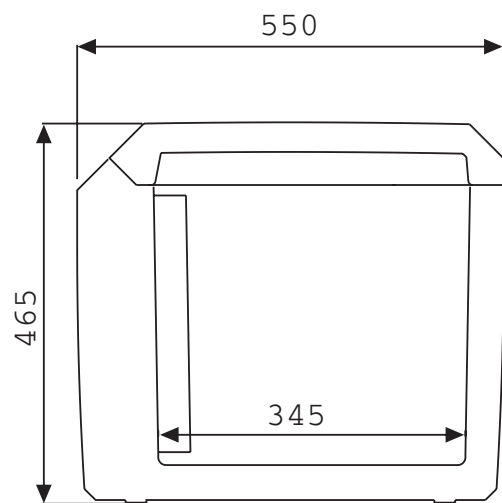

2

## TC-Serie

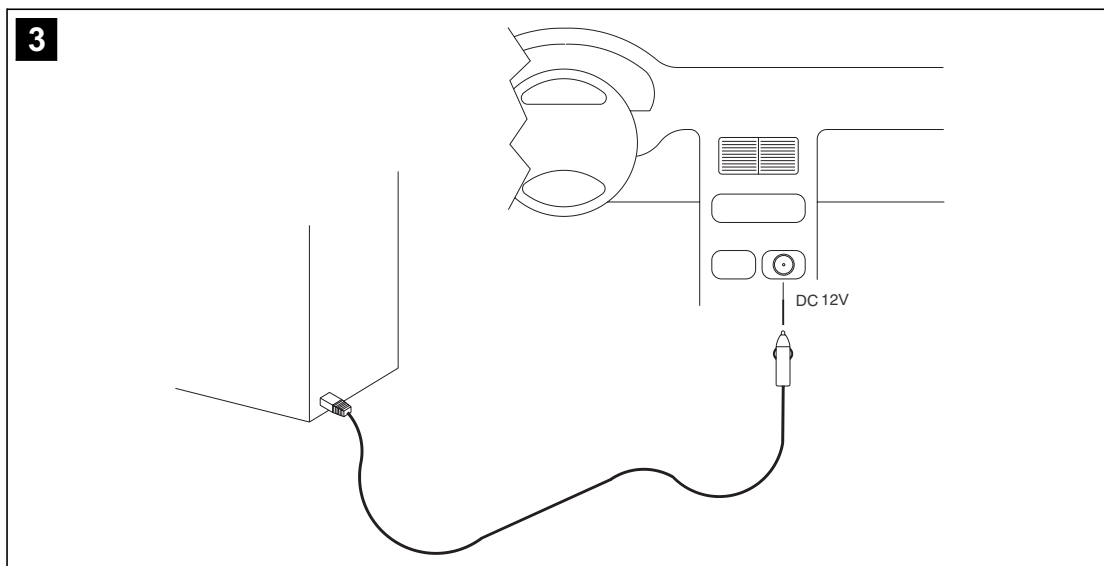
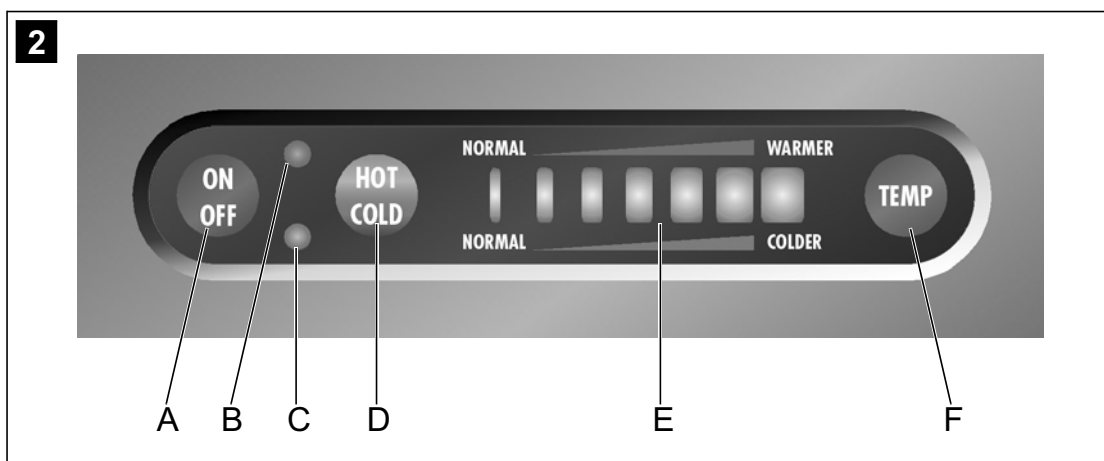

**Read these instructions carefully before the installation and commissioning and keep them in a safe place. Pass it on to the buyer in case of the further sale of the device.**

## List of contents

1	Information on using the installation instructions . . . . .	13
2	Safety notes . . . . .	14
3	Scope of delivery . . . . .	15
4	Use as intended . . . . .	15
5	Technical description . . . . .	16
6	Operation . . . . .	16
7	Cleaning and servicing . . . . .	19
8	Disposal . . . . .	19
9	Troubleshooting . . . . .	20
10	Technical data . . . . .	21

## 1 Information on using the installation instructions

The following symbols are used in these operating instructions:



### Caution!

**Safety note:** Failure in observing these warnings may result in injuries to persons or damage of equipment.



### Caution!

**Safety note** which points out the dangers involved with electrical current or electrical voltage: Failure in observing these warnings may result in injuries to persons or damage of equipment and improper functioning of the device.



### Note

Supplementary information on the operation of the device.

- **Action:** This symbol indicates to you that you must do something. The actions necessary are described step by step.
- ✓ This symbol describes the result of an action.

**Please also observe the following safety notes.**

## 2 Safety notes

### 2.1 General safety

- Connect the device only as follows:
  - with the connecting cable contained in the scope of delivery to the alternating current circuit
  - with the connecting cable contained in the scope of delivery to the cigarettelighter in the vehicle (see illustration 3, page 3).
- The appliance shall not be exposed to rain.
- Never pull the plug at the connecting cable out of the cigarettelighter or the socket.
- If the supply cord is damaged, it must be replaced with same type and rating AC cord in order avoid a hazard.
- If the device shows visible damage, you may not put it into operation.
- Repairs on this device may be executed only by specialists. Considerable dangers can occur as a result of improper repairs.  
Contact the customer service in the case WAECO of repairs.
- Disconnect the connecting cable
  - before each cleaning and servicing,
  - after each use.
- Make sure that the venting slots will not be covered!
- With boats: Make sure that with mains operation that your power supply is protected via a FI-switch! **Danger to life!**
- Disconnect your refrigerator and other consuming units from the battery before connecting a fast battery recharger!
- Compare the voltage indicated on the type plate to the present energy supply.
- The refrigerator is not suitable for the transport of corrosive or solvent-based substances!
- Food may only be stored in its original packaging or in suitable containers.

**Electrical devices are no toys!**

Please keep and use the device out of the reach of children.

## 2.2 Safety when operating the device

- Ensure before starting up that supply line and plug are dry.
- Do not place the device in the proximity of open flames or other heat sources (heating, strong solar rays, gas ovens etc.).
- Do not fill any liquids or ice into the interior container.
- Never immerse the device into water.
- Protect the device and the cables against heat and wetness.
- Never grasp with your bare hands the bare lines. This applies above all when operating on the alternating current circuit: **Danger to life!**
- WAECO is not liable for damages which are caused by **non- intended use** or **wrong operation**.

## 3 Scope of delivery

Quantity	Designation
1	Refrigerator
1	Connecting cable for mains operation
1	Connecting cable for cigarette lighter

Check before starting up the device that all parts are available belonging to the scope of delivery.

## 4 Use as intended

The refrigerator can be used to cool and keep foodstuffs warm. The device can be also used for camping purposes.

If you want to cool medicine, check please if the cooling capacity of the device corresponds to the requirements of the respective pharmaceuticals.

All materials processed in the refrigerator are safe for foodstuffs.

## 5 Technical description

The cooling box is suitable for mobile use. It can cool goods up to max. 30 °C under ambient temperature (thermostatic switch-off with approx. +1 °C) or keep them cool or warm them up to max. 65 °C or keep them warm.

If the device has reached the set temperature range, then it will automatically switch over to the energy save mode. In this mode only the energy is consumed which is required to reach the temperature inside the box.

The cooling is a wear and CFC-free thermo-electric cooler with heat removal through a ventilator.

The cooling box is equipped with an automatic priority circuit. Thus it is ensured that with simultaneous connection to the alternating current circuit and to a 12/24-V-battery, the alternating current circuit will be used.

## 6 Operation



Before you put the new refrigerator into operation, you should clean it inside and outside with a damp cloth for hygienic reasons (see also Chapter „Cleaning and servicing“ on page 19).

### 6.1 Tips to save energy



A ventilator in the interior space of the cooling box provides for the circulation of the cold air within the box. Thus a better cooling capacity will be achieved. In order that the cold air cannot reach the outside when opening the cooling box, this is equipped with a switch which turns off the ventilator as soon as the lid is opened.

- Select a well ventilated location which is protected against sunrays.
- Let warm foods first cool down before you bin them.
- Avoid an unnecessary low inside temperature!
- Do not open the refrigerator more often than necessary!
- Do not leave the lid or door open longer than necessary!

## 6.2 Switch on the cooling box

- Place the cooling box on a stable base.



The plug is safe against wrong polarity: You can plug it only in one direction into the (see illustration 3, page 3) socket.

- Connect the cooling box
  - with the connecting cable contained in the scope of delivery to the socket or...
  - with the supplied connecting cable to the cigarette lighter in the vehicle (see illustration 3, page 3).
- Press the button „ON/OFF“ at the control panel (see Illustration 2 A, Page 3) to switch on the cooling box.
- ✓ The cooling box starts to cool or heat the interior space.

### Operating display

### Operating mode

red  
(see Illustration 2 B,  
Page 3)

heating

blue  
(see Illustration 2 C,  
Page 3)

cooling



Take care that there are only objects or goods in the cooling box which may be cooled or heated to the selected temperature.

## 6.3 Switch over between cooling and heating

- If you want to switch over between **cooling** and **heating**, press the button „HOT/COLD“ (see Illustration 2 D, Page 3).



The control unit of the cooling box has a memory function. Thus the temperature range which is previously selected in the mode is set again with each switching on or switching over.

- ✓ The red or blue operating display lights up and the device starts to cool/heat.



- When you want to finish the cooling or heating process, press the button „ON/OFF“ (see Illustration 2 A, Page 3).
- When you put the cooling box out of operation, disconnect the connecting cable.

## 6.4 Select temperature

The status display of the temperature (see Illustration 2 F, Page 3) indicates the selected temperature range. With an increasing number of illuminating LEDs, the intensity of the temperature range also increases.



The following temperature indications are subject to tolerances and are dependent on the measuring position.

Interior space-temperature at approx. 25 °C ambient temperature:

	Status display	Temperature range
<b>Cooling</b>	seven illuminating LEDs	approx 1 °C in the interior space
	an illuminating LED	approx 15 °C in the interior space
<b>Heating</b>	seven illuminating LEDs	approx 65 °C in the interior space
	an illuminating LED	approx 50 °C in the interior space

- If you want to select the temperature to **cool/heat**, press the button “Temp“ (see Illustration 2 F, Page 3), until the requested temperature range is reached.

## 6.5 Connect to the cigarette lighter



When you connect the cooling box to the cigarette lighter of your vehicle (see illustration 3, page 3), observe that you have to turn on the ignition, if necessary, so that the device is supplied with current.

## 7 Cleaning and servicing

**Caution!**

Disconnect the connecting cable from the socket or cigarette lighter before each cleaning of the cooling box.

**Caution!**

Never clean the cooling box under running water or even in rinsing water.

**Caution!**

Do not use any mordant detergents or hard objects since these can damage the cooling box.

- Clean the cooling box inside from time to time with a damp cloth.
- Clean the outside of the device with a damp cloth.

## 8 Disposal

- Place the packaging material in the appropriate recycling waste bins wherever possible.







If you wish to finally dispose of the device, ask your local recycling centre or specialist dealer for details about how to do this in accordance with the applicable disposal regulations.

## 9 Troubleshooting

Fault	Possible cause	Suggestion
Your box does not function and the fan impeller which is visible from outside does not rotate.	The cigarette lighter in your vehicle does not conduct any voltage.	In the most vehicles, the ignition switch must be switched on, so that the cigarette lighter has voltage.
The ignition is switched on and the box does not work. Disconnect the plug immediately from the socket and execute the following checks.	The socket of the cigarette lighter is dirty. This results in a poor electrical contact.	Clean the socket of the cigarette lighter with a non-metallic brush and a solvent, so that the middle contact pin is clean. If your cooling box plug becomes very warm in the cigarette lighter box, either the socket must be cleaned or the plug is possibly not correctly assembled.
	The fuse of the connecting cable is burnt through.	Replace the fuse of the connecting cable (5 A).
	The vehicle fuse is burnt through.	Replace the vehicle fuse of the cigarette lighter (usually 15 A). (Observe the operating instructions in your motorcar for this).
Your box does not cool satisfactorily and the fan impeller at the outside does not rotate.	The ventilator motor is defective.	The repair can be executed only by an authorized customer service.
Your box does not cool satisfactorily and the fan impeller at the outside does not rotate.	The ventilator motor for the inner ventilator is defective.	The repair can be executed only by an authorized customer service.
	The thermo-electric element is defective.	
	The integrated power unit is defective.	The repair can be executed only by an authorized customer service.

## 10 Technical data

	TC-14FL-AC	TC-21FL-AC	TC-35FL-AC
Content:	14 l	21 l	35 l
Input voltage:	12/24 volts DC/220-240 volts AC		
Power input:	46 watts (12 volts DC) or 50 watts (24 volts DC) or 64 watts (220-240 volts AC) <b>For Australia:</b> 43 watts (12 volts DC) or 50 watts (24 volts DC) or 63 watts (220-240 volts AC)		
Temperature range:	Cooling: up to approx. 1 °C interior space- temperature (up to 30 °C under ambient temperature) Heating: up to approx. 65 °C interior space- temperature		
Weight:	5,5 kg	7 kg	10 kg
Inspection/ Certificate:	    		

The device is free of CFC and is accredited with the GS-sign for passing a safety check.

Subject to changes due to technical progress and availability.

# WAECO

## mobile solutions

### Headquarters

**D** **WAECO International GmbH** · Hollefeldstraße 63 · D-48282 Emsdetten  
Fon: +49 2572 879-195 · Fax: +49 2572 879-322 · E-Mail: info@waeco.de · Internet: www.waeco.de

### Europe

**CH** **WAECO Schweiz AG**  
Riedackerstrasse 7a  
CH-8153 Rümlang (Zürich)  
Fon: +41 1 8187171  
Fax: +41 1 8187191  
E-Mail: info@waeco.ch

**DK** **WAECO Danmark A/S**  
Tværvej 2  
DK-6640 Lunderskov  
Fon: +45 75585966  
Fax: +45 75586307  
E-Mail: waeco@waeco.dk

**E** **WAECO Ibérica S.A.**  
Camí del Mig, 106  
Poligono Industrial Les Corts  
E-08349 Cabrera de Mar  
(Barcelona)  
Fon: +34 93 7502277  
Fax: +34 93 7500552  
E-Mail: info@waeco.es

**F** **WAECO Distribution SARL**  
ZAC 2 · Les Portes de L'Oise  
Rue Isaac Newton – BP 59  
F-60230 Chambly (France)  
Fon: +33 1 30282020  
Fax: +33 1 30282010  
E-Mail: info@waeco.fr

**FIN** **WAECO Finland OY**  
Mestarintie 4  
FIN-01730 Vantaa  
Fon: +358 20 7413220  
Fax: +358 9 7593700  
E-Mail: waeco@waeco.fi

**I** **WAECO Italcold SRL**  
Zona Industriale Sartiano, 298/9  
I-61015 Novafeltria  
Fon: +39 0541 920827  
Fax: +39 0541 920237  
E-Mail: sales@waecoitalia.it

**N** **WAECO Norge AS**  
Leif Weldingsvei 16  
N-3208 Sandefjord  
Fon: +47 33428450  
Fax: +47 33428459  
E-Mail: firmapost@waeco.no

**NL** **WAECO Benelux B.V.**  
Postbus 1461 · Ettenseweg 60  
NL-4700 BL Roosendaal  
Fon: +31 165 586700  
Fax: +31 165 555562  
E-Mail: verkoop@waeco.nl

**S** **WAECO Svenska AB**  
Gustaf Melins gata 7  
S-42131 Västra Frölunda  
(Göteborg)  
Fon: +46 31 7341100  
Fax: +46 31 7341101  
E-Mail: info@waeco.se

**UK** **WAECO UK Ltd.**  
Dorset DT2 8LY · Unit G  
Roman Hill Business Park  
UK-Broadmayne  
Fon: +44 1305 854000  
Fax: +44 1305 854288  
E-Mail: sales@waeco.co.uk

### Overseas + Middle East

**AUS** **WAECO Pacific Pty. Ltd.**  
1 John Duncan Court  
Varsity Lakes QLD 4227  
Fon: +61 7 55076000  
Fax: +61 7 55221003  
E-Mail: sales@waeco.com.au

**HK** **WAECO Impex Ltd.**  
Headquarters  
Suites 3210-12 · 32/F · Tower 2  
The Gateway · 25 Canton Road  
Tsim Sha Tsui · Kowloon  
Hong Kong  
Fon: +852 2 4632750  
Fax: +8 52 24639067  
E-Mail: info@waeco.com.hk

**ROC** **WAECO Impex Ltd.**  
Taipei Office  
2 FL-3 · No. 56 Tunhua South Rd, Sec 2  
Taipei 106, Taiwan  
Fon: +886 2 27014090  
Fax: +886 2 27060119  
E-Mail: marketing@waeco.com.tw

**UAE** **WAECO Middle East FZCO**  
R/A 8, SD 6  
Jebel Ali, Dubai  
Fon: +971 4 8833858  
Fax: +971 4 8833868  
E-Mail: waeco@emirates.net.ae

**USA** **WAECO USA, Inc.**  
8 Heritage Park Road  
Clinton, CT 06413  
Fon: +1 860 6644911  
Fax: +1 860 6644912  
E-Mail: customercare@waecousa.com

 [www.waeco.com](http://www.waeco.com)



4445100164\_09/2005