

RANGE

2010

TENTS · SLEEPING BAGS · DAYSACS · RUCSACS · FURNITURE · ACCESSORIES



  
easy camp®

## THE EASY CAMP® RANGE 2010

Welcome to the 2010 catalogue from Easy Camp® with a completely updated range of products for all types of camper – young or old.

The relaxed atmosphere of a simple life out camping promotes a friendliness that you do not often see at home. The natural feeling of saying 'good morning' to your neighbours even though they are strangers, likely from a different part of the world. Chatting over a cup of tea or glass of wine, spontaneous alfresco family lunches or just relaxing with a book with just the countryside to keep you company – is there more to ask for in life.

For 2010 we are offering a totally overhauled collection of tents, sleeping bags and rucsacs focused into 4 broad categories.

**CARNIVAL** is very much about the youth of today, intelligent and mobile. This range is light and bright, easy to use and exudes an element of fun. Perfect for anything from a weekend festival to an adventurous outing.

**EXPLORER** is for just that, getting out and being part of the outdoors; weekends away, enjoying the outdoors environment – the possibilities are endless. This collection is extensive with all products packed with feature at great value prices.

The **GO** range is a collection of quality, eye catching tents that are aimed at regular users looking for good performance with the style to match.

**TOUR** is for holiday camping, great value and enjoyment. Whether it is family camping or friends touring, this range offers a size and budget for everyone.

In addition we have created a desirable range of must-have accessories suitable for the requirements of today's campers, offering a full and comprehensive selection of products from cookware to lighting to furniture and maintaining our great value message.



# CONTENTS



<b>TENTS</b> _____	<b>4</b>
<b>CARNIVAL Range</b> _____	<b>6</b>
<b>EXPLORER Range</b> _____	<b>20</b>
<b>GO Range</b> _____	<b>32</b>
<b>TOUR Range</b> _____	<b>40</b>
<b>SLEEPING BAGS</b> _____	<b>56</b>
<b>COMIC Range</b> _____	<b>60</b>
<b>COSMOS Range</b> _____	<b>62</b>
<b>ASTRO Range</b> _____	<b>64</b>
<b>DEVIL Range</b> _____	<b>66</b>
<b>LITE Range</b> _____	<b>67</b>
<b>ATLANTA Range</b> _____	<b>68</b>
<b>SELF-INFLATING MATS AND AIRBEDS</b> _____	<b>70</b>
<b>TRAVEL SHEETS</b> _____	<b>73</b>
<b>FURNITURE</b> _____	<b>74</b>
<b>Folding Furniture - Lime</b> _____	<b>76</b>
<b>Folding Furniture - Blue</b> _____	<b>80</b>
<b>Camping Furniture</b> _____	<b>84</b>
<b>Cupboards</b> _____	<b>86</b>
<b>Kitchen Tables</b> _____	<b>87</b>
<b>Tables</b> _____	<b>88</b>
<b>Picnic Tables</b> _____	<b>90</b>
<b>RUCSACS / DAYSACS</b> _____	<b>92</b>
<b>Picnic</b> _____	<b>97</b>
<b>ACCESSORIES</b> _____	<b>98</b>
<b>Kettles</b> _____	<b>100</b>
<b>Cook sets</b> _____	<b>101</b>
<b>Cooking &amp; Cooking utensils</b> _____	<b>103</b>
<b>Tableware</b> _____	<b>106</b>
<b>Bottles</b> _____	<b>107</b>
<b>Cutlery</b> _____	<b>108</b>
<b>Lightning</b> _____	<b>110</b>
<b>Water Carriers</b> _____	<b>112</b>
<b>Pegs, mallet, pump, guylines</b> _____	<b>113</b>
<b>Repair Kits</b> _____	<b>115</b>

## CARNIVAL

CARNIVAL is for being young and having fun. People who have a variety of hobbies and activities from going to festivals, overnight camping with friends and ultimately enjoying the freedom of the outdoor environment. This range of products is all about being attractive, getting noticed, being easy to use and simple to understand, modern and inexpensive. Now featuring Fire Retardant and Waterproof Fabrics with fully taped seams and fast, easy pitching.

Name	Hydrostatic head	Sleeps	Pitching	Inner height	Pack size	Weight	Page
Antic - Chilli Pepper	1500 mm	2	Quick erect, single skin	95 cm	68 x 4 cm	1.8 kg	08
Antic - Horizon Blue	1500 mm	2	Quick erect, single skin	95 cm	68 x 4 cm	1.8 kg	09
Antic - Macaw Green	1500 mm	2	Quick erect, single skin	95 cm	68 x 4 cm	1.8 kg	10
Antic - Violet	1500 mm	2	Quick erect, single skin	95 cm	68 x 4 cm	1.8 kg	11
Jester - Chilli Pepper	1500 mm	2	Quick erect, single skin	95 cm	76 x 5 cm	2.1 kg	12
Jester - Horizon Blue	1500 mm	2	Quick erect, single skin	95 cm	76 x 5 cm	2.1 kg	13
Jester - Macaw Green	1500 mm	2	Quick erect, single skin	95 cm	76 x 5 cm	2.1 kg	14
Jester - Violet	1500 mm	2	Quick erect, single skin	95 cm	76 x 5 cm	2.1 kg	15
Tipi - Chilli Pepper	1500 mm	4	Flysheet first, single skin	275 cm	55 x 15 cm	4.1 kg	16
Tipi - Horizon Blue	1500 mm	4	Flysheet first, single skin	275 cm	55 x 15 cm	4.1 kg	17
Tipi - Macaw Green	1500 mm	4	Flysheet first, single skin	275 cm	55 x 15 cm	4.1 kg	18
Tipi - Violet	1500 mm	4	Flysheet first, single skin	275 cm	55 x 15 cm	4.1 kg	19

## EXPLORER

EXPLORER is about getting out and seeing the world outside. Weekends near the lakes, biking in the forest parks, sleeping in the valleys. This range of products will do the job without costing the earth. Suitable for those starting out on their camping experiences, the range consists of many tried and trusted models now with a new look. From simple single skin domes to the larger family 4-berth tents, there is a size and style for everyone. Now featuring Fire Retardant and Waterproof fabrics with fully taped seams, good ventilation and easy pitching.

Name	Hydrostatic head	Sleeps	Pitching	Inner height	Pack size	Weight	Page
Star 100	1500 mm	1	Flysheet first or as one	80 cm	50 x 12 cm	1.9 kg	22
Star 200	1500 mm	2	Flysheet first or as one	95 cm	55 x 15 cm	2.7 kg	23
Comet 200	1500 mm	2	Flysheet first or as one	100 cm	60 x 10 cm	1.8 kg	24
Meteor 200	1500 mm	2	Flysheet first or as one	100 cm	60 x 10 cm	2.4 kg	25
Meteor 300	1500 mm	3	Flysheet first or as one	110 cm	60 x 14 cm	2.8 kg	25
Eclipse 200	1500 mm	2	Flysheet first or as one	110 cm	54 x 16 cm	4.1 kg	26
Eclipse 300	1500 mm	3	Flysheet first or as one	120 cm	54 x 20 cm	4.7 kg	27
Eclipse 400	1500 mm	4	Flysheet first or as one	150 cm	65 x 20 cm	6.8 kg	28
Eclipse 500	1500 mm	4	Flysheet first or as one	190 cm	61 x 23 cm	10.5 kg	29
Galaxy 400	1500 mm	4	Flysheet first or as one	190 cm	58 x 28 cm	12.5 kg	30
Planet 300	1500 mm	3	Flysheet first or as one	180 cm	60 x 22 cm	8.9 kg	31

## GO

GO is about versatility, performance and dependability. A unique looking range aimed at regular users looking for that desirable design and high specification level, whilst maintaining affordability. Strong, lightweight and compact this range offers a good sleeping area, great storage space and easy to manage pack sizes. Now featuring Fire Retardant and Waterproof fabrics with fully taped seams, good ventilation and easy pitching with porch groundsheets and good size interiors.

Name	Hydrostatic head	Sleeps	Pitching	Inner height	Pack size	Weight	Page
Spirit 200	3000 mm	2	Flysheet first or as one	100 cm	56 x 18 cm	4.5 kg	34
Spirit 300	3000 mm	3	Flysheet first or as one	110 cm	59 x 20 cm	5.3 kg	34
Spirit 400	3000 mm	4	Flysheet first or as one	130 cm	61 x 21 cm	6.7 kg	35
Shadow 200	3000 mm	2	Flysheet first or as one	100 cm	58 x 16 cm	3.7 kg	36
Shadow 300	3000 mm	3	Flysheet first or as one	120 cm	59 x 18 cm	4.8 kg	36
Phantom 200	3000 mm	2	Flysheet first or as one	110 cm	58 x 16 cm	4.2 kg	37
Phantom 300	3000 mm	3	Flysheet first or as one	120 cm	58 x 18 cm	5.2 kg	37
Phantom 400	3000 mm	4	Flysheet first or as one	130 cm	60 x 22 cm	6.2 kg	38
Phantom 500	3000 mm	5	Flysheet first or as one	175 cm	60 x 24 cm	8.7 kg	39

## TOUR

TOUR offers good features, great value and surprising performance levels for the family or group either starting out in camping or wanting a dependable yet affordable tent. The entire range consists of large living areas with sewn-in groundsheets for enhanced internal protection. Carefully positioned ventilation allows for maximum airflow, keeping the interior cooler during the summer months. Now featuring Fire Retardant and Waterproof fabrics with fully taped seams, good ventilation and sewn-in groundsheets with spacious interiors.

Name	Hydrostatic head	Sleeps	Pitching	Inner height	Pack size	Weight	Page
Baltimore 300	3000 mm	3	Flysheet first or as one	185 cm	75 x 25 cm	12.0 kg	42
Baltimore 400	3000 mm	4	Flysheet first or as one	190 cm	75 x 32 cm	14.5 kg	43
Boston 400	3000 mm	4	Flysheet first or as one	180 cm	65 x 30 cm	15.2 kg	44
Boston 500	3000 mm	5	Flysheet first or as one	200 cm	68 x 32 cm	17.0 kg	45
Boston 600	3000 mm	6	Flysheet first or as one	200 cm	74 x 31 cm	22.3 kg	46
Canopy	3000 mm	-	Flysheet first, single skin	210 cm	90 x 16 cm	9.2 kg	47
Topeka 600	3000 mm	6	Flysheet first or as one	210 cm	80 x 50 cm	23.5 kg	48
Topeka 800	3000 mm	8	Flysheet first or as one	220 cm	80 x 40 cm	27.1 kg	49
Daytona	3000 mm	-	Flysheet first or as one	210 cm	66 x 24 cm	12.4 kg	50
Sebring 200	3000 mm	2	Flysheet first or as one	210 cm	68 x 26 cm	17.4 kg	51
Great Wall	3000 mm	-	-	-	65 x 15 cm	4.5 kg	52
Annexe	3000 mm	-	Flysheet first, single skin	190 cm	102 x 23 cm	7.5 kg	53
Beach	500 mm	-	Flysheet first, single skin	110 cm	55 x 10 cm	1.3 kg	54
Ocean M	500 mm	-	Flysheet first, single skin	100 cm	60 x 5 cm	1.3 kg	55
Ocean L	500 mm	-	Flysheet first, single skin	115 cm	65 x 6 cm	1.6 kg	55

**CARNIVAL** is for being young and having fun. People who have a variety of hobbies and activities from going to festivals, overnight camping with friends and ultimately enjoying the freedom of the outdoor environment. This range of products is all about being attractive, getting noticed, being easy to use and simple to understand, modern and inexpensive. Now featuring Fire Retardent and Waterproof Fabrics with fully taped seams and fast, easy pitching.





Door with mosquito net



Ventilation



An amazing little tent for 2 people! Just unzip the carry bag, take the tent out and allow it to set itself in an instant – a dream come true – camping without the tent pitching. There is no need to connect or insert any poles; the integral pole system is designed to allow the tent to erect itself. Pegs and guylines are supplied and are advised to increase the stability of the tent in adverse conditions.

The Antic's are ideal for any occasion where you desire a fast and easy tent to pitch, available in a range of bright colours to lift the gloomiest of camp sites.

### SPECIFICATIONS

Item no.:	300091
Flysheet:	180T polyester PU coated F/R
Hydrostatic head:	1500 mm
Taping:	Flysheet fully taped
Pitching:	Quick erect, single skin
Floor:	Polyethylene
Poles:	Fibreglass 6.0 mm
Pack size:	Dia. 68 x 4 cm
Weight:	App. 1.8 kg

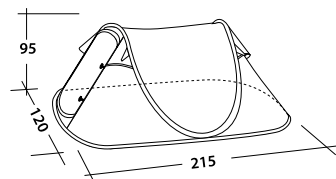
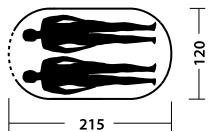

Door with mosquito net



Ventilation



An amazing little tent for 2 people! Just unzip the carry bag, take the tent out and allow it to set itself in an instant – a dream come true – camping without the tent pitching. There is no need to connect or insert any poles; the integral pole system is designed to allow the tent to erect itself. Pegs and guylines are supplied and are advised to increase the stability of the tent in adverse conditions.

The Antic's are ideal for any occasion where you desire a fast and easy tent to pitch, available in a range of bright colours to lift the gloomiest of camp sites.

### SPECIFICATIONS

Item no.:	300092
Flysheet:	180T polyester PU coated F/R
Hydrostatic head:	1500 mm
Taping:	Flysheet fully taped
Pitching:	Quick erect, single skin
Floor:	Polyethylene
Poles:	Fibreglass 6.0 mm
Pack size:	Dia. 68 x 4 cm
Weight:	App. 1.8 kg

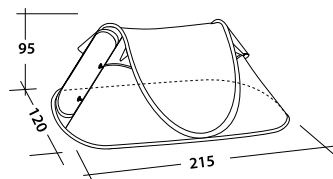
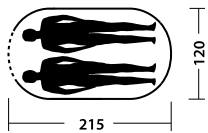

fire  
retardant  
ISO 6940



waterproof  
1500mm HH



taped  
seams



flexible  
pole frame



comfortably  
sleeps



anti-bug  
mesh

Door with mosquito net



Ventilation



An amazing little tent for 2 people! Just unzip the carry bag, take the tent out and allow it to set itself in an instant – a dream come true – camping without the tent pitching. There is no need to connect or insert any poles; the integral pole system is designed to allow the tent to erect itself. Pegs and guylines are supplied and are advised to increase the stability of the tent in adverse conditions.

The Antic's are ideal for any occasion where you desire a fast and easy tent to pitch, available in a range of bright colours to lift the gloomiest of camp sites.

**SPECIFICATIONS**

Item no.:	300093
Flysheet:	180T polyester PU coated F/R
Hydrostatic head:	1500 mm
Taping:	Flysheet fully taped
Pitching:	Quick erect, single skin
Floor:	Polyethylene
Poles:	Fibreglass 6.0 mm
Pack size:	Dia. 68 x 4 cm
Weight:	App. 1.8 kg

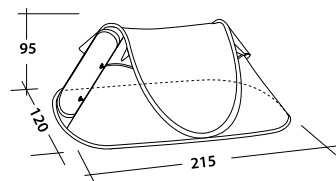
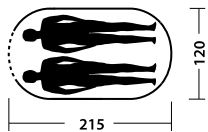

fire retardant  
ISO 6940



waterproof  
1500mm HH



taped seams



flexible pole frame



comfortably sleeps  
2



anti-bug mesh

Door with mosquito net



Ventilation



An amazing little tent for 2 people! Just unzip the carry bag, take the tent out and allow it to set itself in an instant – a dream come true – camping without the tent pitching. There is no need to connect or insert any poles; the integral pole system is designed to allow the tent to erect itself. Pegs and guylines are supplied and are advised to increase the stability of the tent in adverse conditions.

The Antic's are ideal for any occasion where you desire a fast and easy tent to pitch, available in a range of bright colours to lift the gloomiest of camp sites.

**SPECIFICATIONS**

Item no.:	300094
Flysheet:	180T polyester PU coated F/R
Hydrostatic head:	1500 mm
Taping:	Flysheet fully taped
Pitching:	Quick erect, single skin
Floor:	Polyethylene
Poles:	Fibreglass 6.0 mm
Pack size:	Dia. 68 x 4 cm
Weight:	App. 1.8 kg

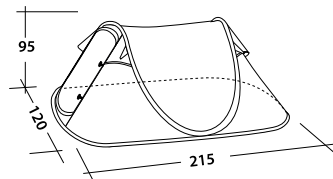
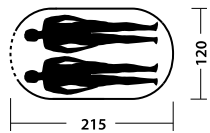

fire retardant  
ISO 6940



waterproof  
1500mm HH



taped seams



flexible pole frame



comfortably sleeps  
2



anti-bug mesh

Door with mosquito net



Ventilation



The big brother to the Antic: larger sleeping area, more head-height and side entry to maximize the internal space.

An amazing tent for 2 people! Just unzip the carry bag, take the tent out and allow it to suit itself in an instant – a dream come true – camping without the tent pitching. There is no need to connect or insert any poles; the integral pole system is designed to allow the tent to erect itself. Pegs and guylines are supplied and are advised to increase the stability of the tent in adverse conditions.

The Jester's are ideal for any occasion where you desire a fast and easy tent to pitch, available in a range of bright colours to lift the gloomiest of camp sites.

### SPECIFICATIONS

Item no.:	300095
Flysheet:	180T polyester PU coated F/R
Hydrostatic head:	1500 mm
Taping:	Flysheet fully taped
Pitching:	Quick erect, single skin
Floor:	Polyethylene
Poles:	Fibreglass 6.0 mm
Pack size:	Dia. 76 x 5 cm
Weight:	App. 2.1 kg

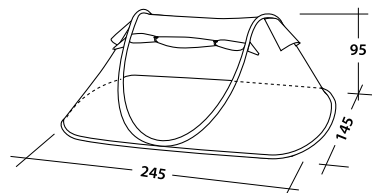
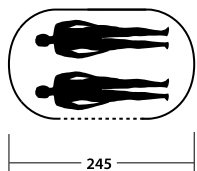

fire  
retardant  
ISO 6940



waterproof  
1500mm HH



taped  
seams



flexible  
pole frame



comfortably  
sleeps



anti-bug  
mesh

Door with mosquito net



Ventilation



The big brother to the Antic: larger sleeping area, more head-height and side entry to maximize the internal space.

An amazing tent for 2 people! Just unzip the carry bag, take the tent out and allow it to suit itself in an instant – a dream come true – camping without the tent pitching. There is no need to connect or insert any poles; the integral pole system is designed to allow the tent to erect itself. Pegs and guylines are supplied and are advised to increase the stability of the tent in adverse conditions.

The Jester's are ideal for any occasion where you desire a fast and easy tent to pitch, available in a range of bright colours to lift the gloomiest of camp sites.

## SPECIFICATIONS

Item no.:	300096
Flysheet:	180T polyester PU coated F/R
Hydrostatic head:	1500 mm
Taping:	Flysheet fully taped
Pitching:	Quick erect, single skin
Floor:	Polyethylene
Poles:	Fibreglass 6.0 mm
Pack size:	Dia. 76 x 5 cm
Weight:	App. 2.1 kg

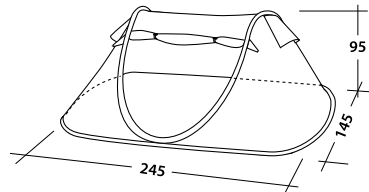
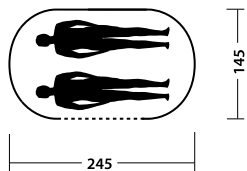

fire  
retardant  
ISO 6940



waterproof  
1500mm HH



taped  
seams



flexible  
pole frame



comfortably  
sleeps



anti-bug  
mesh

Door with mosquito net



Ventilation



The big brother to the Antic: larger sleeping area, more head-height and side entry to maximize the internal space.

An amazing tent for 2 people! Just unzip the carry bag, take the tent out and allow it to suit itself in an instant – a dream come true – camping without the tent pitching. There is no need to connect or insert any poles; the integral pole system is designed to allow the tent to erect itself. Pegs and guylines are supplied and are advised to increase the stability of the tent in adverse conditions.

The Jester's are ideal for any occasion where you desire a fast and easy tent to pitch, available in a range of bright colours to lift the gloomiest of camp sites.

### SPECIFICATIONS

Item no.:	300097
Flysheet:	180T polyester PU coated F/R
Hydrostatic head:	1500 mm
Taping:	Flysheet fully taped
Pitching:	Quick erect, single skin
Floor:	Polyethylene
Poles:	Fibreglass 6.0 mm
Pack size:	Dia. 76 x 5 cm
Weight:	App. 2.1 kg

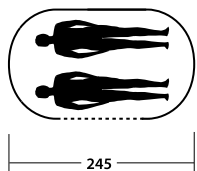

145

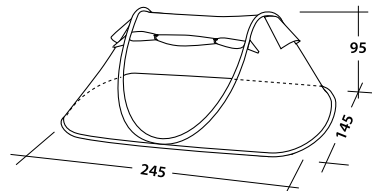

fire  
retardant  
ISO 6940



waterproof  
1500mm HH



taped  
seams



flexible  
pole frame



comfortably  
sleeps



anti-bug  
mesh

Door with mosquito net



Ventilation



The big brother to the Antic: larger sleeping area, more head-height and side entry to maximize the internal space.

An amazing tent for 2 people! Just unzip the carry bag, take the tent out and allow it to suit itself in an instant – a dream come true – camping without the tent pitching. There is no need to connect or insert any poles; the integral pole system is designed to allow the tent to erect itself. Pegs and guylines are supplied and are advised to increase the stability of the tent in adverse conditions.

The Jester's are ideal for any occasion where you desire a fast and easy tent to pitch, available in a range of bright colours to lift the gloomiest of camp sites.

## SPECIFICATIONS

Item no.:	300098
Flysheet:	180T polyester PU coated F/R
Hydrostatic head:	1500 mm
Taping:	Flysheet fully taped
Pitching:	Quick erect, single skin
Floor:	Polyethylene
Poles:	Fibreglass 6.0 mm
Pack size:	Dia. 76 x 5 cm
Weight:	App. 2.1 kg

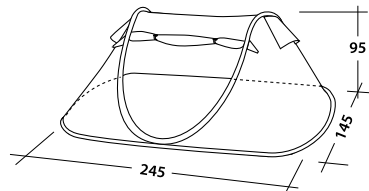
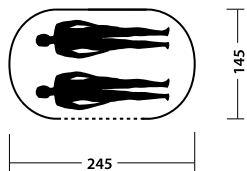

fire  
retardant  
ISO 6940



waterproof  
1500mm HH



taped  
seams



flexible  
pole frame



comfortably  
sleeps



anti-bug  
mesh

Door with mosquito net



A little retro, but a lot of fun! The Tipi tents will stand out on any festival, camp site or back-garden party. Available in a range of bright and fun colours. These tents can be used as a camping shelter, play tent, visual centre piece, meeting area or palatial accommodation. The choice is yours.

### SPECIFICATIONS

Item no.:	300101
Flysheet:	180T polyester PU coated F/R
Hydrostatic head:	1500 mm
Taping:	Flysheet fully taped
Pitching:	Flysheet first
Floor:	Polyethylene
Poles:	Steel pole 16 mm
Pack size:	55 x 15 cm
Weight:	App. 4.1 kg

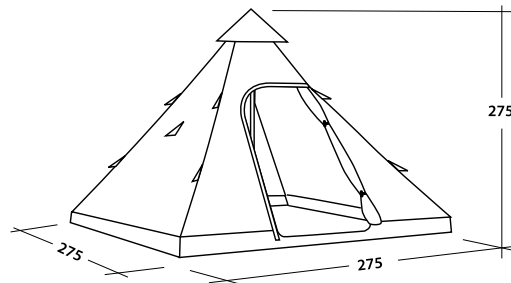
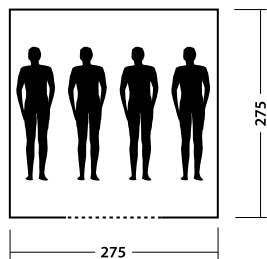

fire  
retardant  
ISO 6940



waterproof  
1500mm HH



taped  
seams



comfortably  
sleeps



anti-bug  
mesh

Door with mosquito net



A little retro, but a lot of fun! The Tipi tents will stand out on any festival, camp site or back-garden party. Available in a range of bright and fun colours. These tents can be used as a camping shelter, play tent, visual centre piece, meeting area or palatial accommodation. The choice is yours.

### SPECIFICATIONS

Item no.:	300102
Flysheet:	180T polyester PU coated F/R
Hydrostatic head:	1500 mm
Taping:	Flysheet fully taped
Pitching:	Flysheet first
Floor:	Polyethylene
Poles:	Steel pole 16 mm
Pack size:	55 x 15 cm
Weight:	App. 4.1 kg

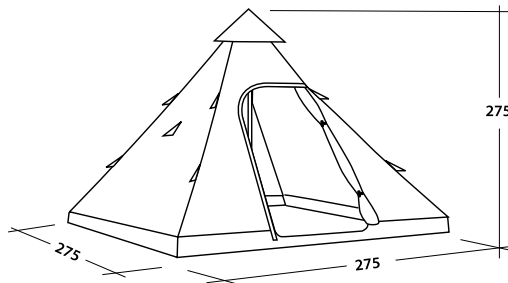
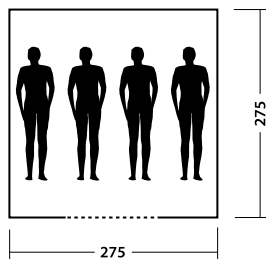

fire  
retardant  
ISO 6940



waterproof  
1500mm HH



taped  
seams



comfortably  
sleeps



anti-bug  
mesh

Door with mosquito net



A little retro, but a lot of fun! The Tipi tents will stand out on any festival, camp site or back-garden party. Available in a range of bright and fun colours. These tents can be used as a camping shelter, play tent, visual centre piece, meeting area or palatial accommodation. The choice is yours.

### SPECIFICATIONS

Item no.:	300103
Flysheet:	180T polyester PU coated F/R
Hydrostatic head:	1500 mm
Taping:	Flysheet fully taped
Pitching:	Flysheet first
Floor:	Polyethylene
Poles:	Steel pole 16 mm
Pack size:	55 x 15 cm
Weight:	App. 4.1 kg

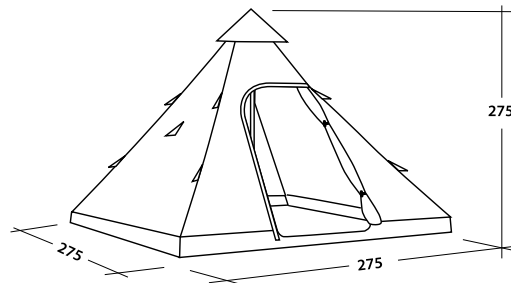
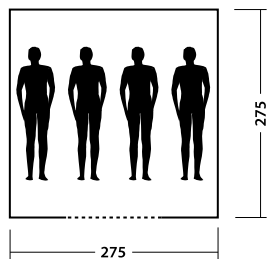

fire  
retardant  
ISO 6940



waterproof  
1500mm HH



taped  
seams



comfortably  
sleeps



anti-bug  
mesh

Door with mosquito net



A little retro, but a lot of fun! The Tipi tents will stand out on any festival, camp site or back-garden party. Available in a range of bright and fun colours. These tents can be used as a camping shelter, play tent, visual centre piece, meeting area or palatial accommodation. The choice is yours.

### SPECIFICATIONS

Item no.:	300104
Flysheet:	180T polyester PU coated F/R
Hydrostatic head:	1500 mm
Taping:	Flysheet fully taped
Pitching:	Flysheet first
Floor:	Polyethylene
Poles:	Steel pole 16 mm
Pack size:	55 x 15 cm
Weight:	App. 4.1 kg

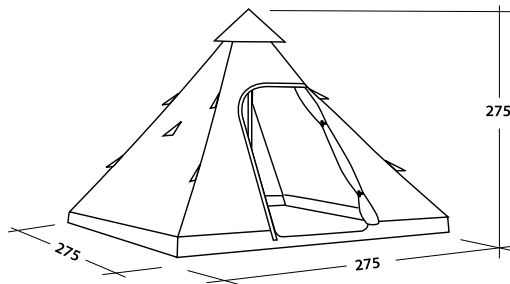
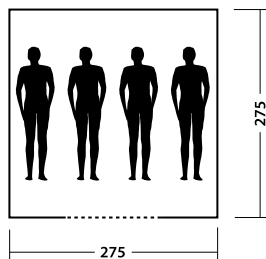

fire  
retardant  
ISO 6940



waterproof  
1500mm HH



taped  
seams



comfortably  
sleeps



anti-bug  
mesh

EXPLORER is about getting out and seeing the world outside. Weekends near the lakes, biking in the forest parks, sleeping in the valleys. This range of products will do the job without costing the earth. Suitable for those starting out on their camping experiences, the range consists of many tried and trusted models now with a new look. From simple single skin domes to the larger family 4-berth tents, there is a size and style for everyone. Now featuring Fire Retardant and Waterproof fabrics with fully taped seams, good ventilation and easy pitching.





Front and rear ventilation



Lantern point



Small, simple and stable; this tent is lightweight with a very small pack size making it ideal for starting out in camping or backpacking.

### SPECIFICATIONS

Item no.:	300153
Flysheet:	180T polyester PU coated F/R
Hydrostatic head:	1500 mm
Taping:	Flysheet fully taped
Pitching:	Flysheet first
Inner tent:	Breathable polyester
Floor:	Polyethylene
Poles:	Fibreglass 7.9 mm
Pack size:	50 x 12 cm
Weight:	App. 1.9 kg

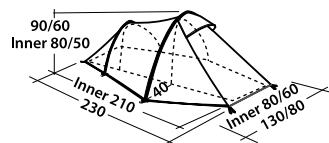
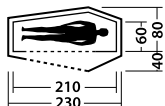

fire  
retardant  
ISO 6940



waterproof  
1500mm HH



taped  
seams



flexible  
pole frame



lantern  
point



anti-bug  
mesh

Double side door opening



A larger version of the 100, this tent is lightweight with a very small pack size but has a larger bedroom suitable for 2 people. The total weight can be split between two, making it ideal for starting out in camping or backpacking.

### SPECIFICATIONS

Item no.:	300155
Flysheet:	180T polyester PU coated F/R
Hydrostatic head:	1500 mm
Taping:	Flysheet fully taped
Pitching:	Flysheet first
Inner tent:	Breathable polyester
Floor:	Polyethylene
Poles:	Fibreglass 8.5 mm
Pack size:	55 x 15 cm
Weight:	App. 2.7 kg

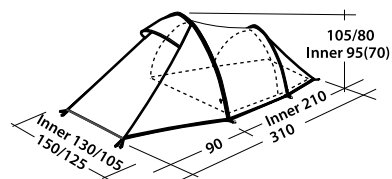
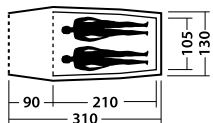

fire  
retardant  
ISO 6940



waterproof  
1500mm H<sub>2</sub>O



taped  
seams



comfortably  
sleeps



flexible  
pole frame



lantern  
point



anti-bug  
mesh



A simple, classic, single skin dome tent with additional roof ventilation for improved air circulation. Generally considered as a first timer's tent, it makes an ideal shelter to trial a few nights outside.

### SPECIFICATIONS

Item no.:	300152
Flysheet:	180T polyester PU coated F/R
Hydrostatic head:	1500 mm
Taping:	Flysheet fully taped
Pitching:	Flysheet first
Floor:	Polyethylene
Poles:	Fibreglass 7.9 mm
Pack size:	60 x 10 cm
Weight:	App. 1.8 kg

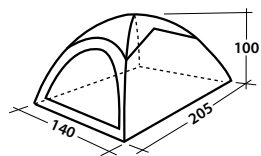
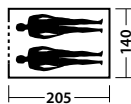

fire  
retardant  
ISO 6940



waterproof  
1500mm HH



taped  
seams



flexible  
pole frame



comfortably  
sleeps



anti-bug  
mesh

Top ventilation



Dome tents - the tent standard for camping across the world. The Meteor has an inner tent and a porch area for storage. Ventilation has been added to improve air circulation. This is the ideal tent for starting camping adventures and can be used in a variety of situations.

### SPECIFICATIONS

Item no.:	300157 / 300158
Flysheet:	180T polyester PU coated F/R
Hydrostatic head:	1500 mm
Taping:	Flysheet fully taped
Pitching:	Flysheet first
Inner tent:	Breathable polyester
Floor:	Polyethylene
Poles:	Fibreglass 7.9 mm
Pack size:	60 x 10 / 60 x 14 cm
Weight:	App. 2.4 / 2.8 kg

200

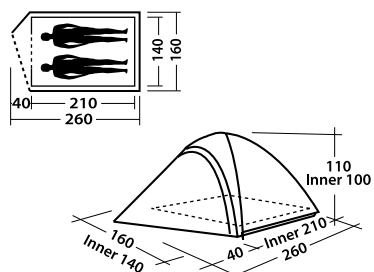

300

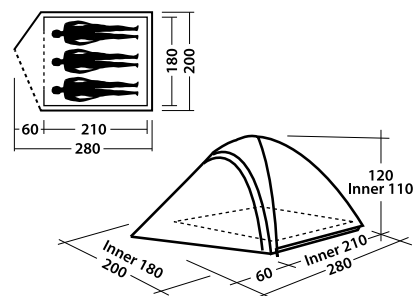

fire  
retardant  
ISO 6940



waterproof  
1500mm HH



taped  
seams



flexible  
pole frame



comfortably  
sleeps



comfortably  
sleeps



anti-bug  
mesh

Ventilation



Front opening



Utilising the simplicity of a dome shaped tent, with an extended tunnel storage area makes for a very versatile shelter. We offer this model in a variety of sizes as it has a variety of uses. From family camping with the larger 400 model offering head height and living room; to bike touring where all the equipment, including the bikes, can be stored in the porch; to more general camping where lots of extra room with the large porch areas is an obvious benefit. Two access door enhances the versatility with a porch groundsheet included for ground protection.

### SPECIFICATIONS

Item no.:	300159
Flysheet:	180T polyester PU coated F/R
Hydrostatic head:	1500 mm
Taping:	Flysheet fully taped
Pitching:	Flysheet first
Inner tent:	Breathable polyester
Floor:	Polyethylene
Poles:	Fibreglass 7.9 / 8.5 mm
Accessories:	Detachable groundsheet for porch area
Pack size:	54 x 16 cm
Weight:	App. 4.1 kg

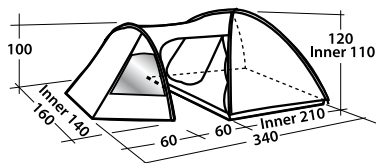
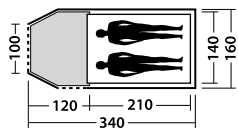

fire  
retardant  
ISO 6940



waterproof  
1500mm HH



taped  
seams



flexible  
pole frame



comfortably  
sleeps



anti-bug  
mesh

Front door opening



Organizer pocket



Utilising the simplicity of a dome shaped tent, with an extended tunnel storage area makes for a very versatile shelter. We offer this model in a variety of sizes as it has a variety of uses. From family camping with the larger 400 model offering head height and living room; to bike touring where all the equipment, including the bikes, can be stored in the porch; to more general camping where lots of extra room with the large porch areas is an obvious benefit. Two access door enhances the versatility with a porch groundsheet included for ground protection.

### SPECIFICATIONS

Item no.:	300160
Flysheet:	180T polyester PU coated F/R
Hydrostatic head:	1500 mm
Taping:	Flysheet fully taped
Pitching:	Flysheet first
Inner tent:	Breathable polyester
Floor:	Polyethylene
Poles:	Fibreglass 7.9 / 8.5 mm
Accessories:	Detachable groundsheet for porch area
Pack size:	54 x 20 cm
Weight:	App. 4.7 kg

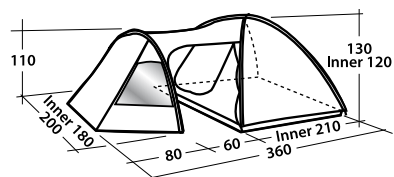
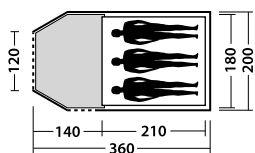

fire  
retardant  
ISO 6940



waterproof  
1500mm HH



taped  
seams



flexible  
pole frame



comfortably  
sleeps



anti-bug  
mesh

Front door opening



Organizer pocket



Utilising the simplicity of a dome shaped tent, with an extended tunnel storage area makes for a very versatile shelter. We offer this model in a variety of sizes as it has a variety of uses. From family camping with the larger 400 model offering head height and living room; to bike touring where all the equipment, including the bikes, can be stored in the porch; to more general camping where lots of extra room with the large porch areas is an obvious benefit. Two access door enhances the versatility with a porch groundsheet included for ground protection.

### SPECIFICATIONS

Item no.:	300162
Flysheet:	180T polyester PU coated F/R
Hydrostatic head:	1500 mm
Taping:	Flysheet fully taped
Pitching:	Flysheet first
Inner tent:	Breathable polyester
Floor:	Polyethylene
Poles:	Fibreglass 8.5 / 9.5 mm
Accessories:	Detachable groundsheet for porch area
Pack size:	65 x 20 cm
Weight:	App. 6.8 kg

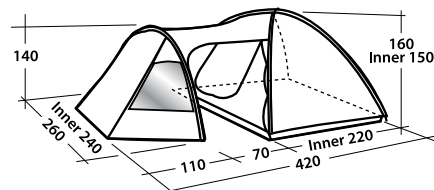
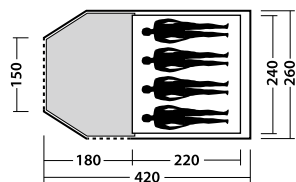

Front door opening



Organizer pocket



Utilising the simplicity of a dome shaped tent, with an extended tunnel storage area makes for a very versatile shelter. We offer this model in a variety of sizes as it has a variety of uses. From family camping with the larger 400 model offering head height and living room; to bike touring where all the equipment, including the bikes, can be stored in the porch; to more general camping where lots of extra room with the large porch areas is an obvious benefit. Two access door enhances the versatility with a porch groundsheet included for ground protection.

### SPECIFICATIONS

Item no.:	300165
Flysheet:	180T polyester PU coated F/R
Hydrostatic head:	1500 mm
Taping:	Flysheet fully taped
Pitching:	Flysheet first
Inner tent:	Breathable polyester
Floor:	Polyethylene
Poles:	Fibreglass 9.5 / 11.0 mm
Accessories:	Detachable groundsheet for porch area
Pack size:	61 x 23 cm
Weight:	App. 10.5 kg

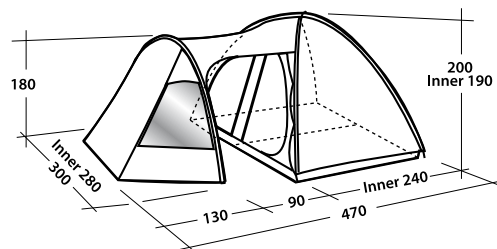
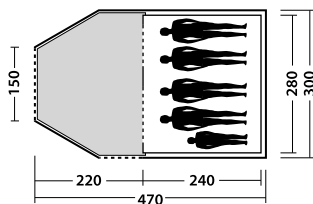

fire  
retardant  
ISO 6940



waterproof  
1500mm HH



taped  
seams



flexible  
pole frame



standing  
room



comfortably  
sleeps



anti-bug  
mesh

Front door opening



Organizer pocket



The largest tent in the Explorer range offers full head height, large porch space and a spacious bedroom area. The hoop pole construction allows the Galaxy to be pitched quickly and easily. Two access doors enhances the versatility with a porch groundsheet included for ground protection. Great value family camping.

### SPECIFICATIONS

Item no.:	300167
Flysheet:	180T polyester PU coated F/R
Hydrostatic head:	1500 mm
Taping:	Flysheet fully taped
Pitching:	Flysheet first
Inner tent:	Breathable polyester
Floor:	Polyethylene
Poles:	Fibreglass 11.0 mm
Accessories:	2 upright steel canopy poles Detachable groundsheet for porch area
Pack size:	58 x 28 cm
Weight:	App. 12.5 kg

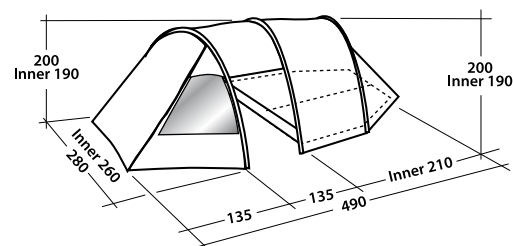
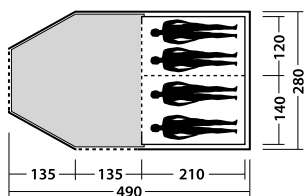

fire  
retardant  
ISO 6940



waterproof  
1500mm HH



taped  
seams



flexible  
pole frame



standing  
room



comfortably  
sleeps



anti-bug  
mesh

Front door opening



Organizer pocket



A compact family tent that offers a good sleeping area, head height and stability. Two access door enhances the versatility with a porch groundsheet included for ground protection. Ideal as a touring tent where it will be moved regularly or as a smaller family tent.

### SPECIFICATIONS

Item no.:	300166
Flysheet:	180T polyester PU coated F/R
Hydrostatic head:	1500 mm
Taping:	Flysheet fully taped
Pitching:	Flysheet first
Inner tent:	Breathable polyester
Floor:	Polyethylene
Poles:	Fibreglass 9.5 / 11.0 mm
Accessories:	2 upright steel canopy poles Detachable groundsheet for porch area
Pack size:	60 x 22 cm
Weight:	App. 8.9 kg

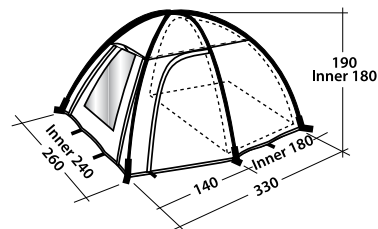
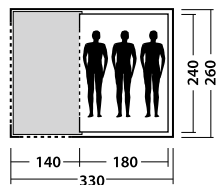

fire  
retardant  
ISO 6940



waterproof  
1500mm HH



taped  
seams



flexible  
pole frame



standing  
room



comfortably  
sleeps



anti-bug  
mesh



**GO** is about versatility, performance and dependability. A unique looking range aimed at regular users looking for that desirable design and high specification level, whilst maintaining affordability. Strong, lightweight and compact this range offers a good sleeping area, great storage space and easy to manage pack sizes. Now featuring Fire Retardant and Waterproof fabrics with fully taped seams, good ventilation and easy pitching with porch groundsheets and good size interiors.



Front door opening



A versatile tunnel design offering a large porch for storage, double entrances, additional ventilation and spacious bedroom areas. A real multi purpose tent which is favoured for the additional storage space the porch offers. Often used for cycle or motorcycle touring but can be used for a variety of camping applications. Now with a porch groundsheet included for ground protection.

## SPECIFICATIONS

Item no.:	300178 / 300179
Flysheet:	185T polyester PU coated F/R
Hydrostatic head:	3000 mm
Taping:	Flysheet fully taped
Pitching:	Flysheet first or as one
Inner tent:	Breathable polyester
Floor:	Polyethylene
Poles:	Fibreglass 7.9 / 8.5 mm
Accessories:	Porch area groundsheet attached to inner tent
Pack size:	56 x 18 / 59 x 20 cm
Weight:	App. 4.5 / 5.3 kg

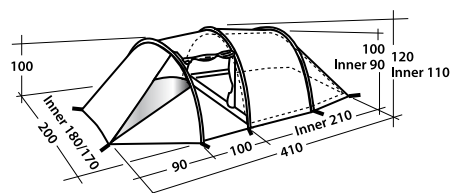
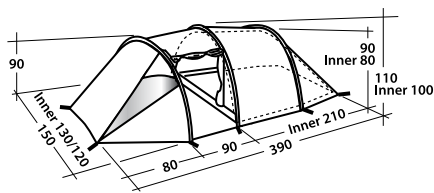
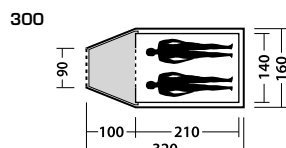
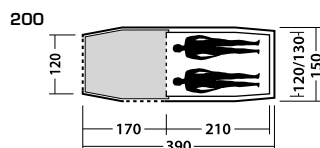

GO

35



# SPIRIT 400

Front door opening



A versatile tunnel design offering a large porch for storage, double entrances, additional ventilation and spacious bedroom areas. A real multi purpose tent which is favoured for the additional storage space the porch offers. Often used for cycle or motorcycle touring but can be used for a variety of camping applications. Now with a porch groundsheet included for ground protection.

## SPECIFICATIONS

Item no.:	300180
Flysheet:	185T polyester PU coated F/R
Hydrostatic head:	3000 mm
Taping:	Flysheet fully taped
Pitching:	Flysheet first or as one
Inner tent:	Breathable polyester
Floor:	Polyethylene
Poles:	Fibreglass 9.5 mm
Accessories:	Porch area groundsheet attached to inner tent
Pack size:	61 x 21 cm
Weight:	App. 6.7 kg

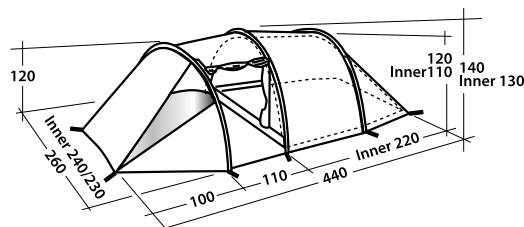
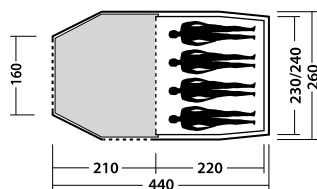

fire  
retardant  
ISO 6940



waterproof  
3000mm HH



taped  
seams



flexible  
pole frame



comfortably  
sleeps



anti-bug  
mesh

Ventilation



A compact and lightweight tunnel tent with exceptional internal space. Easy to pitch and pack-up, it is ideal for camping ventures where weight is important. The simple tunnel construction maximises the usable internal space. Now with a porch groundsheet included for ground protection.

## SPECIFICATIONS

Item no.:	300174 / 300175
Flysheet:	185T polyester PU coated F/R
Hydrostatic head:	3000 mm
Taping:	Flysheet fully taped
Pitching:	Flysheet first or as one
Inner tent:	Breathable polyester
Floor:	Polyethylene
Poles:	Fibreglass 7.9 / 8.5 mm
Accessories:	Porch area groundsheet attached to inner tent
Pack size:	58 x 16 / 59 x 18 cm
Weight:	App. 3.7 / 4.8 kg

200

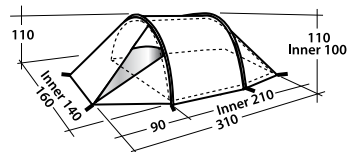
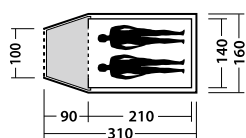

300

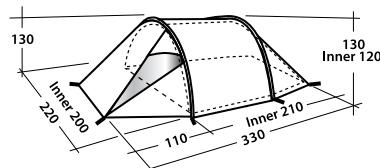
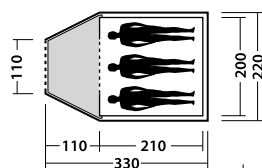

Window / Ventilation



A classic dome tent in an eye-catching style and colour. Dome tents are a good, compact dependable structure that is tried and trusted in the Easy Camp range. Everyone should have one of these tents. We have given this classic tent a facelift and added some features as well. Now with a porch groundsheet included for ground protection.

### SPECIFICATIONS

Item no.:	300181 / 300183
Flysheet:	185T polyester PU coated F/R
Hydrostatic head:	3000 mm
Taping:	Flysheet fully taped
Pitching:	Flysheet first or as one
Inner tent:	Breathable polyester
Floor:	Polyethylene
Poles:	Fibreglass 7.9 / 8.5 mm
Accessories:	Porch area groundsheet attached to inner tent
Pack size:	58 x 16 / 58 x 18 cm
Weight:	App. 4.2 / 5.2 kg

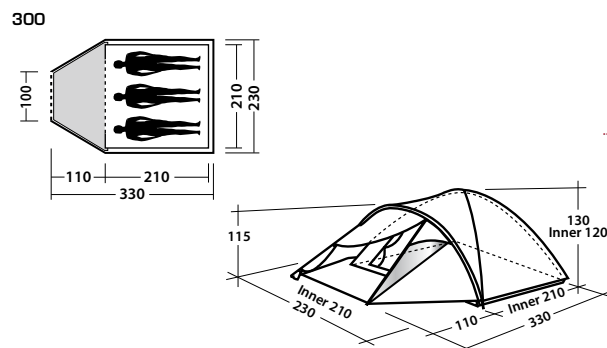
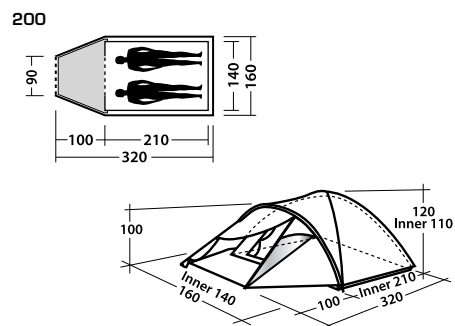

Window / Ventilation



A classic dome tent in an eye-catching style and colour. Dome tents are a good, compact dependable structure that is tried and trusted in the Easy Camp range. Everyone should have one of these tents. We have given this classic tent a facelift and added some features as well. Now with a porch groundsheet included for ground protection.

### SPECIFICATIONS

Item no.:	300240
Flysheet:	185T polyester PU coated F/R
Hydrostatic head:	3000 mm
Taping:	Flysheet fully taped
Pitching:	Flysheet first or as one
Inner tent:	Breathable polyester
Floor:	Polyethylene
Poles:	Fibreglass 8.5 / 9.5 mm
Accessories:	Porch area groundsheet attached to inner tent
Pack size:	60 x 22 cm
Weight:	App. 6.2 kg

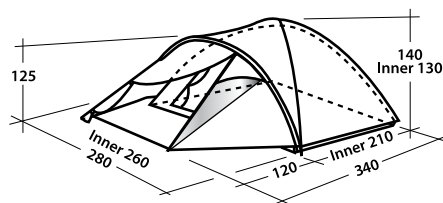
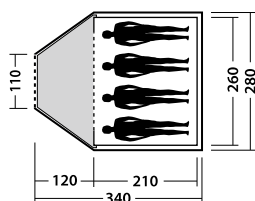

fire  
retardant  
ISO 6940



waterproof  
3000mm HH



taped  
seams



flexible  
pole frame



comfortably  
sleeps



anti-bug  
mesh

Window / Ventilation



A classic dome tent in an eye-catching style and colour. Dome tents are a good, compact dependable structure that is tried and trusted in the Easy Camp range. Everyone should have one of these tents. We have given this classic tent a facelift and added some features as well. Now with a porch groundsheet included for ground protection.

### SPECIFICATIONS

Item no.:	300241
Flysheet:	185T polyester PU coated F/R
Hydrostatic head:	3000 mm
Taping:	Flysheet fully taped
Pitching:	Flysheet first or as one
Inner tent:	Breathable polyester
Floor:	Polyethylene
Poles:	Fibreglass 9.5 / 11.0 mm
Accessories:	Porch area groundsheet attached to inner tent
Pack size:	60 x 24 cm
Weight:	App. 8.7 kg

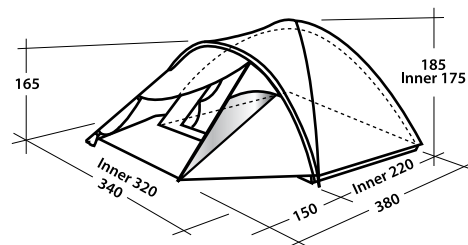
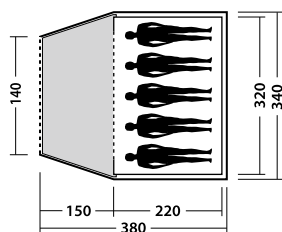

fire  
retardant  
ISO 6940



waterproof  
3000mm HH



taped  
seams



flexible  
pole frame



standing  
room



comfortably  
sleeps



anti-bug  
mesh



**TOUR** offers good features, great value and surprising performance levels for the family or group either starting out in camping or wanting a dependable yet affordable tent. The entire range consists of large living areas with sewn-in groundsheets for enhanced internal protection. Carefully positioned ventilation allows for maximum airflow, keeping the interior cooler during the summer months. Now featuring Fire Retardant and Waterproof fabrics with fully taped seams, good ventilation and fully sewn-in groundsheets with spacious interiors.



A range of modern tunnel tents offering spacious bedrooms and large living areas with large panoramic windows for extra light and unobstructed viewing when inside. All models now have a fully integrated groundsheet throughout to offer the best protection and have updated features such as cable entry points, hanging loops and well thought out ventilation options. These are highly practical tents for family camping.

Sewn-in groundsheet

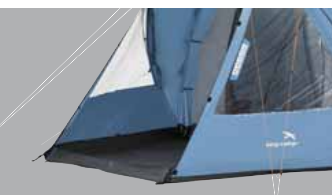

Mains access



## SPECIFICATIONS

Item no.:	300261
Flysheet:	185T polyester PU coated F/R
Hydrostatic head:	3000 mm
Taping:	Flysheet fully taped
Pitching:	Flysheet first or as one
Inner tent:	Breathable polyester
Floor:	Polyethylene
Poles:	Fibreglass 11.0 mm
Accessories:	2 upright steel canopy poles
Pack size:	75 x 25 cm
Weight:	App. 12.0 kg

### Optional extras

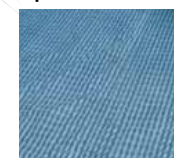

520715 Carpet



520724 Footprint

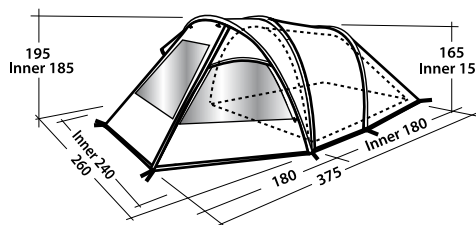
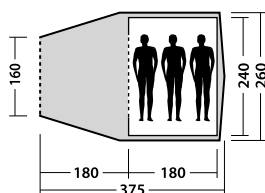

fire  
retardant  
ISO 6940



waterproof  
3000mm H<sub>2</sub>O



taped  
seams



flexible  
pole frame



sewn-in  
groundsheet



standing  
room



comfortably  
sleeps



mains  
access

Sewn-in groundsheet



Mains access



A range of modern tunnel tents offering spacious bedrooms and large living areas with large panoramic windows for extra light and unobstructed viewing when inside. All models now have a fully integrated groundsheet throughout to offer the best protection and have updated features such as cable entry points, hanging loops and well thought out ventilation options. These are highly practical tents for family camping.

## SPECIFICATIONS

Item no.:	300262
Flysheet:	185T polyester PU coated F/R
Hydrostatic head:	3000 mm
Taping:	Flysheet fully taped
Pitching:	Flysheet first or as one
Inner tent:	Breathable polyester
Floor:	Polyethylene
Poles:	Fibreglass 11.0 mm
Accessories:	2 upright steel canopy poles
Pack size:	75 x 32 cm
Weight:	App. 14.5 kg

### Optional extras

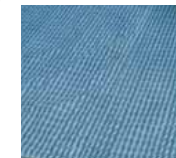

520716 Carpet



520725 Footprint

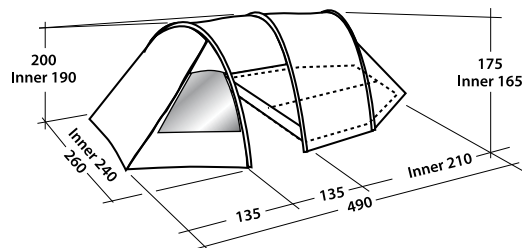
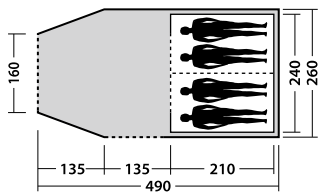

fire  
retardant  
ISO 6940



waterproof  
3000mm HW



taped  
seams



flexible  
pole frame



sewn-in  
groundsheet



standing  
room



comfortably  
sleeps



mains  
access

Sewn-in groundsheet



Ventilation



A new model developed by the team at Easy Camp offering all the benefits of a large tunnel tent combined with a front awning to offer protection for the entrance. The very light and bright front porch area allows for chairs and tables as well as other equipment to be in a comfortable and inviting setting, even on gloomy days. The bedrooms are large, separated by a zip divider to offer privacy. The size and features of this Boston range make it an interesting choice for families searching for a modern looking tent.

**SPECIFICATIONS**

Item no.:	300265
Flysheet:	185T polyester PU coated F/R
Hydrostatic head:	3000 mm
Taping:	Flysheet fully taped
Pitching:	Flysheet first or as one
Inner tent:	Breathable polyester
Floor:	Polyethylene
Poles:	Fibreglass 13.0 mm
Pack size:	65 x 30 cm
Weight:	App. 15.2 kg

**Optional extras**

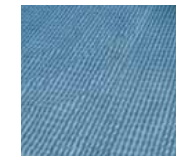

520719 Carpet



520728 Footprint

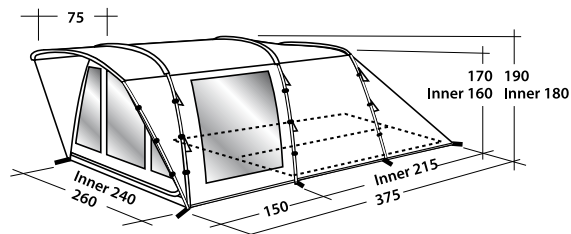
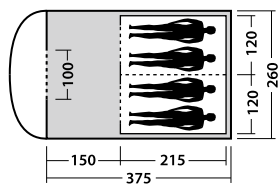

fire retardant ISO 6940



waterproof 3000mm H<sub>2</sub>O



taped seams



flexible pole frame



sewn-in groundsheet



standing room



comfortably sleeps



mains access

A new model developed by the team at Easy Camp offering all the benefits of a large tunnel tent combined with a front awning to offer protection for the entrance. The very light and bright front porch area allows for chairs and tables as well as other equipment to be in a comfortable and inviting setting, even on gloomy days. The bedrooms are large, separated by a zip divider to offer privacy. The size and features of this Boston range make it an interesting choice for families searching for a modern looking tent.

Sewn-in groundsheet



Ventilation



**SPECIFICATIONS**

Item no.:	300266
Flysheet:	185T polyester PU coated F/R
Hydrostatic head:	3000 mm
Taping:	Flysheet fully taped
Pitching:	Flysheet first or as one
Inner tent:	Breathable polyester
Floor:	Polyethylene
Poles:	Fibreglass 13.0 mm
Pack size:	68 x 32 cm
Weight:	App. 17.0 kg

Optional extras

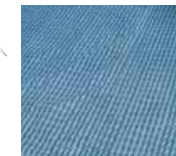

520720 Carpet



520729 Footprint

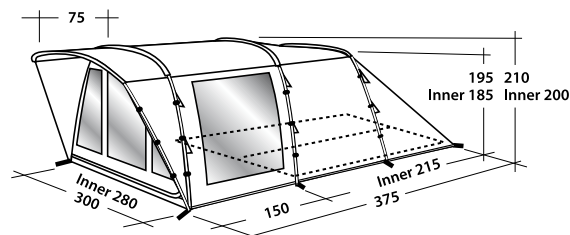
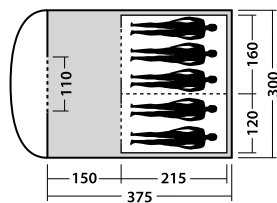

fire retardant ISO 6940



waterproof 3000mm HH



flexible pole frame



sewn-in groundsheet



standing room



comfortably sleeps



mains access

A new model developed by the team at Easy Camp offering all the benefits of a large tunnel tent combined with a front awning to offer protection for the entrance. The very light and bright front porch area allows for chairs and tables as well as other equipment to be in a comfortable and inviting setting, even on gloomy days. The bedrooms are large, separated by a zip divider to offer privacy. The size and features of this Boston range make it an interesting choice for families searching for a modern looking tent.

Sewn-in groundsheet



Ventilation



**SPECIFICATIONS**

Item no.:	300267
Flysheet:	185T polyester PU coated F/R
Hydrostatic head:	3000 mm
Taping:	Flysheet fully taped
Pitching:	Flysheet first or as one
Inner tent:	Breathable polyester
Floor:	Polyethylene
Poles:	Fibreglass 13.0 mm
Pack size:	74 x 31 cm
Weight:	App. 22.3 kg

**Optional extras**

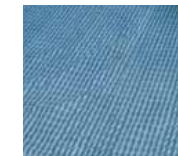

520721 Carpet



520730 Footprint

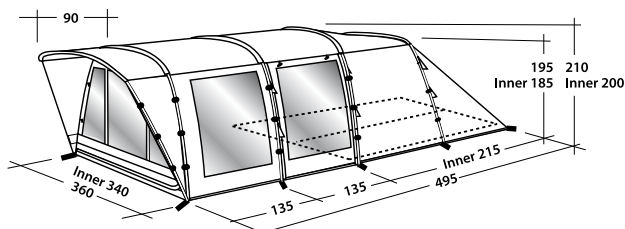
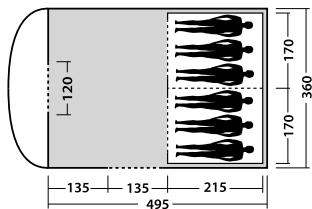

fire retardant ISO 6940



waterproof 3000mm H<sub>2</sub>O



taped seams



flexible pole frame



sewn-in groundsheet



standing room



comfortably sleeps 6



mains access



A great way to extend your outdoor living and storage area as well as offering more protection to the front of the tent. This canopy will fit on all TOUR tents.

### SPECIFICATIONS

Item no.:	300268
Flysheet:	185T polyester PU coated F/R
Hydrostatic head:	3000 mm
Taping:	Flysheet fully taped
Poles:	Steel poles 16.0 mm
Pack size:	90 x 16 cm
Weight:	App. 9.2 kg

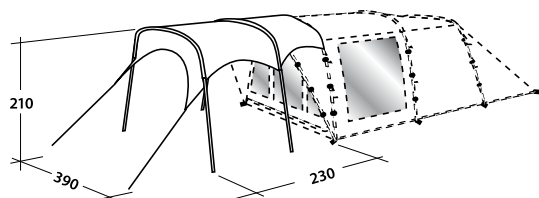

fire  
retardant  
ISO 6940



waterproof  
3000mm HH



taped  
seams



steel  
pole frame



standing  
room

Sewn-in groundsheet



The flexibility of 3 separate bedrooms makes this range worth considering if members of the family want their own space or you wish to invite friends along on your next camping holiday. The large living area in the dome allows for best use of the space and offers maximum headroom due to the height of the poles. Hanging loops and cable entry points are sewn-in for that extra luxury of electrics in the tent (some campsites have electric hook-ups). An extended porch at the entrance allows for the extra storage space for shoes and jackets in order to keep the main living area clean and dry. Ideal for family camping.

### SPECIFICATIONS

Item no.:	300263
Flysheet:	185T polyester PU coated F/R
Hydrostatic head:	3000 mm
Taping:	Flysheet fully taped
Pitching:	Flysheet first or as one
Inner tent:	Breathable polyester
Floor:	Polyethylene
Poles:	Fibreglass 11.0 / 13.0 mm
Accessories:	2 upright steel canopy poles
Pack size:	80 x 50 cm
Weight:	App. 23.5 kg

### Optional extras

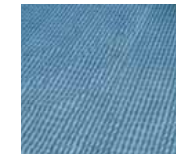

520717 Carpet

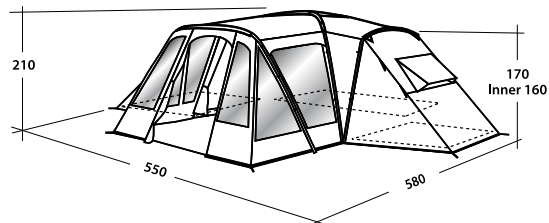
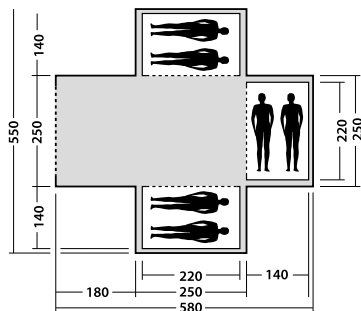

520726 Footprint

 fire  
retardant  
ISO 6940

 waterproof  
3000mm H<sub>2</sub>O

 taped  
seams

 flexible  
pole frame

 sewn-in  
groundsheet

 standing  
room

 comfortably  
sleeps

 mains  
access

Sewn-in groundsheet



The flexibility of 3 separate bedrooms makes this range worth considering if members of the family want their own space or you wish to invite friends along on your next camping holiday. The large living area in the dome allows for best use of the space and offers maximum headroom due to the height of the poles. Hanging loops and cable entry points are sewn-in for that extra luxury of electrics in the tent (some campsites have electric hook-ups). An extended porch at the entrance allows for the extra storage space for shoes and jackets in order to keep the main living area clean and dry. Ideal for family camping.

### SPECIFICATIONS

Item no.:	300264
Flysheet:	185T polyester PU coated F/R
Hydrostatic head:	3000 mm
Taping:	Flysheet fully taped
Pitching:	Flysheet first or as one
Inner tent:	Breathable polyester
Floor:	Polyethylene
Poles:	Fibreglass 11.0 / 13.0 mm
Accessories:	2 upright steel canopy poles
Pack size:	80 x 40 cm
Weight:	App. 27.1 kg

### Optional extras

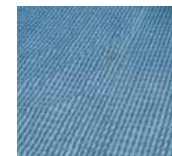

520718 Carpet

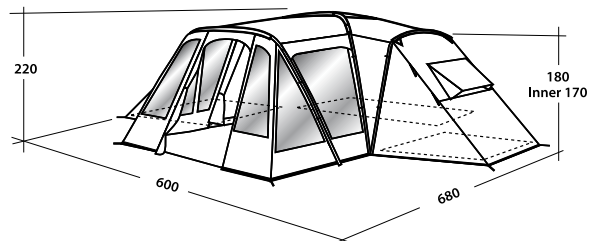
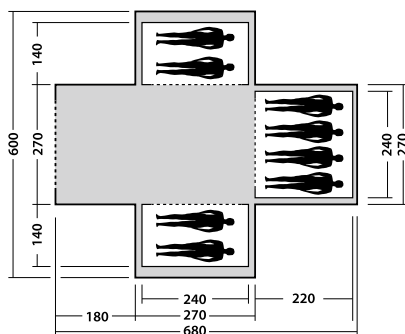

520727 Footprint

fire  
retardant  
ISO 6940waterproof  
3000mm H<sub>2</sub>Otaped  
seamsflexible  
pole framesewn-in  
groundsheetstanding  
roomcomfortably  
sleepsmains  
access

TOUR

50



DAYTONA

A tent for storage or shelter that attaches to the size of a car, van or caravan. Easy and quick to set up makes this ideal for trips where short stays are the norm. No need to spend time sorting the awning, just pack it up and go.

### SPECIFICATIONS

Item no.:	300248
Flysheet:	185T polyester PU coated F/R
Hydrostatic head:	3000 mm
Taping:	Flysheet fully taped
Pitching:	Flysheet first or as one
Inner tent:	Breathable polyester
Floor:	Polyethylene
Poles:	Fibreglass 11.0 mm 2 upright steel poles
Pack size:	66 x 24 cm
Weight:	App. 12.4 kg

Front opening



Mains access



### Optional extras

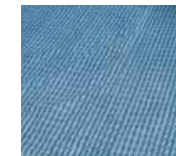

520722 Carpet



520708 Footprint

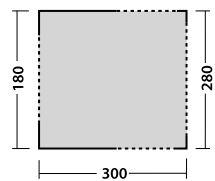

fire retardant  
ISO 6940



waterproof  
3000mm HH



taped seams



flexible pole frame



sewn-in groundsheet



standing room



mains access

This bus tent will attach to most camper vans and feature a large living area. The bedroom can be removed for maximum versatility. Also featuring a sewn-in groundsheet and flexi vents.

### SPECIFICATIONS

Item no.:	300249
Flysheet:	185T polyester PU coated F/R
Hydrostatic head:	3000 mm
Taping:	Flysheet fully taped
Pitching:	Flysheet first or as one
Inner tent:	Breathable polyester
Floor:	Polyethylene
Poles:	Fibreglass 11.0 mm
Accessories:	2 upright steel canopy poles
Pack size:	68 x 26 cm
Weight:	App. 17.4 kg

Front opening



Mains access



Optional extras

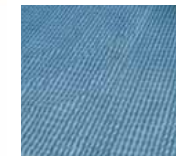

520723 Carpet

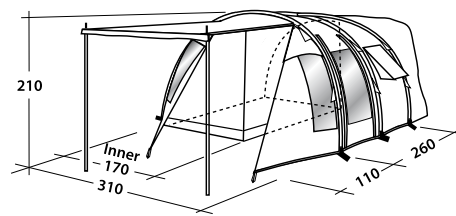
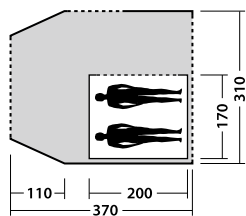

520709 Footprint

fire  
retardant  
ISO 6940waterproof  
3000mm HWtaped  
seamsflexible  
pole framesewn-in  
groundsheetstanding  
roomcomfortably  
sleepsmains  
access

TOUR

52



GREAT WALL

Unique designs for the Easy Camp Windscreen, giving a neat look to add to your tent. Packs neatly away with window view these windscreens will add to your trip away.

### SPECIFICATIONS

Item no.:	300269
Fabric:	185T polyester F/R
Taping:	Flysheet fully taped
Poles:	Steel poles 16 mm
Pack size:	65 x 15 cm
Weight:	App. 4.5 kg

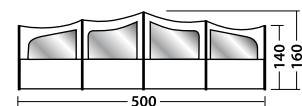

Rear door  
with window/mesh

A very versatile extra for your camping holiday this Annexe provides additional storage for all those family extras, can give shelter and with front or rear door opening it can be used in any position.

### SPECIFICATIONS

Item no.:	300173
Flysheet:	185T polyester PU coated F/R
Hydrostatic head:	3000 mm
Taping:	Flysheet fully taped
Pitching:	Flysheet first
Poles:	Steel poles 16 mm
Accessories:	2 upright steel canopy poles
Pack size:	102 x 23 cm
Weight:	App. 7.5 kg

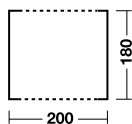

fire  
retardant  
ISO 6940



waterproof  
3000mm H<sub>2</sub>O



taped  
seams



steel  
pole frame



standing  
room



A lightweight, half dome shelter that has an integral groundsheet and small packsize. The Beach is ideal for use on the beach, in the garden or at a festival.

### SPECIFICATIONS

Item no.:	300086
Flysheet:	180T polyester PU coated F/R UV 50+
Hydrostatic head:	500 mm
Floor:	Polyethylene
Poles:	Fibreglass 7.9 mm
Pack size:	55 x 10 cm
Weight:	App. 1.3 kg

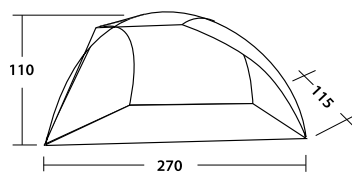
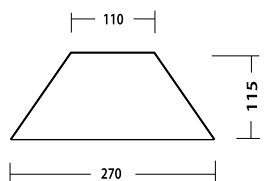

TOUR

55

easy camp®

OCEAN M/L



A funky and functional, pop up shelter that sets up in seconds. Lightweight with a small packsize the Beach is ideal for use on the beach, in the garden or at a festival.

### SPECIFICATIONS

Item no.:	300087 / 300088
Flysheet:	180T polyester PU coated F/R UV 50+
Hydrostatic head:	500 mm
Floor:	Polyethylene
Poles:	Fibreglass 6.0 mm
Pack size:	60 x 5 / 65 x 6 cm
Weight:	App. 1.3 / 1.6 kg

M

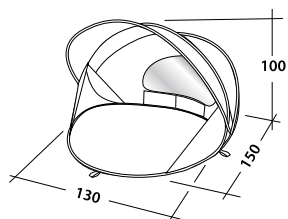
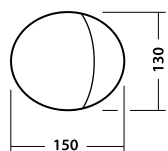

L

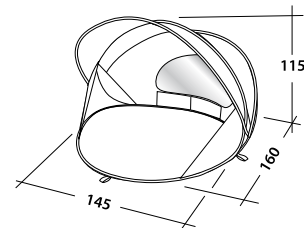
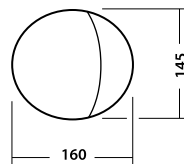



The Easy Camp sleeping bag range has been updated with contemporary new styles and colours and continues with the broad category themes presented within the tent and rucsac ranges. Choose the correct model for the desired activity and ensure that you have a peaceful nights sleep.

**CARNIVAL** is for being young and having fun. People who have a variety of hobbies from going to festivals, overnight camping with friends, short trips throughout Europe and ultimately enjoying the freedom of the outdoor environment. This range of products are about being attractive, easy to use, simple to understand, modern and inexpensive. Soft touch shell fabrics combined with cotton-like linings and hollowfibre fill, make for a good nights sleeping.

**EXPLORER** is about getting out and seeing the world outside. Weekends near the lakes, biking in the forest parks, sleeping in the valleys. This range of products will do the job without costing the earth. Suitable for those starting out with their camping experiences. Soft touch shell fabrics combined with cotton-like linings and hollowfibre fill, make for a good nights sleeping.

**GO** is about versatility, performance and dependability. A unique looking range aimed at regular users looking for that desirable design and specification level, whilst maintaining affordability. Lightweight and compact this range offers a good sleeping solution and easy to manage pack sizes.

**TOUR** offers good features, great value and surprising performance levels for the family or group either starting out in camping or wanting a dependable yet affordable sleeping bag. The range uses a cotton-like soft touch fabric on the shell and lining combined with a warm hollowfibre fill.



Our very successful sleeping bag collection has now been fully updated with new themes, designs and colours.

### OUR SLEEPING BAG RANGE

CARNIVAL	Ideal for caravanning, camping, sleep-overs or festivals
EXPLORER	Most suited to general camping but can be used for caravanning and festivals.
GO	Comprehensive collection of compact items suitable for up to 3-season use. A good camping allrounder.
TOUR	Designed to complement our family camping range.

### SEASON RATINGS

For 2010 we have introduced season ratings for our sleeping bags to make selecting a sleeping bag easier for both retail buyers and consumers:

- 1 SEASON - For use in the Summer months only
- 2 SEASON - For use from late Spring through to early Autumn
- 3 SEASON - For use from Spring right through Autumn
- 4 SEASON - For use throughout all seasons but more suited to colder conditions



- 1. Full length zip baffle prevent heat loss around the zip
- 2. Internal pocket for personal possessions
- 3. Strap for hanging and airing of sleeping bag
- 4. Off-set construction eliminates cold spots
- 5. Anti-snag zip guard
- 6. Large thermo collar for comfort



All our sleeping bags are tested to the EN13537 standards. This test is the official European Standard for the labelling of sleeping bags. It is a complete product standard which defines how to test, measure and label a sleeping bag. The EN13537 applies to all sleeping bags with the exception of sleeping bags for military use and sleeping bags for extreme temperatures.

To determine temperature limits of sleeping bags objectively, the European standard EN 13537 on requirements for sleeping bags specifies the use of a computer-controlled thermal manikin similar in shape and size to the human body. A sleeping bag containing a manikin is placed inside a temperature-controlled climate chamber and tested in accordance with a prescribed procedure to determine the thermal insulation properties of the bag. Recommended temperature limits are based on the insulation properties measured and on knowledge of how the human body reacts to thermal conditions during sleep.

**Tmax:** Upper limit of comfort range. The temperature up to which a partially uncovered sleeping bag user (standard man) just does not perspire too much.

**Tcomfort:** Lower limit of the comfort range down to which a sleeping bag user with a relaxed posture such as lying on the back is globally in equilibrium and just not feeling cold (related to standard woman and in standard condition of use).

**Tlimit:** Lower limit of which a sleeping bag user with curled-up body posture is globally in thermal equilibrium and just not feeling cold (related to standard man and in standard condition of use).

**Textreme:** Lower extreme temperature where the risk of health damage from hypothermia occurs (related to standard woman and in standard conditions of use).

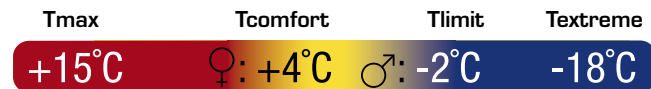

Name	Shell	Lining	Filling	Shape	Weight	EN13537 STD	Season
Comic - Chilli Pepper	190T soft handle polyester	Soft polycotton	1x250 g/m <sup>2</sup> Hollowfibre	Envelope	1250 g	+20°C ♀: +9°C ♂: +5°C -6°C	2
Comic - Macaw	190T soft handle polyester	Soft polycotton	1x250 g/m <sup>2</sup> Hollowfibre	Envelope	1250 g	+20°C ♀: +9°C ♂: +5°C -6°C	2
Comic - Horizon Blue	190T soft handle polyester	Soft polycotton	1x250 g/m <sup>2</sup> Hollowfibre	Envelope	1250 g	+20°C ♀: +9°C ♂: +5°C -6°C	2
Comic - Violet	190T soft handle polyester	Soft polycotton	1x250 g/m <sup>2</sup> Hollowfibre	Envelope	1250 g	+20°C ♀: +9°C ♂: +5°C -6°C	2
Cosmos 150	190T soft handle polyester	Soft polycotton	1x150 g/m <sup>2</sup> Hollowfibre	Mummy	850 g	+22°C ♀: +12°C ♂: +8°C -5°C	1-2
Cosmos 250	190T soft handle polyester	Soft polycotton	1x250 g/m <sup>2</sup> Hollowfibre	Mummy	1100 g	+20°C ♀: +10°C ♂: +5°C -9°C	2
Cosmos 350	190T soft handle polyester	Soft polycotton	1x350 g/m <sup>2</sup> Hollowfibre	Mummy	1100 g	+17°C ♀: +6°C ♂: +1°C -14°C	3
Cosmos Plus	190T soft handle polyester	Soft polycotton	1x250 g/m <sup>2</sup> Hollowfibre	Mummy	1620 g	+18°C ♀: +7°C ♂: +2°C -13°C	2
Astro - Green	190T soft handle polyester	Soft polycotton	1x250 g/m <sup>2</sup> Hollowfibre	Envelope	1360 g	+20°C ♀: +9°C ♂: +4°C -10°C	2
Astro - Navy	190T soft handle polyester	Soft polycotton	1x250 g/m <sup>2</sup> Hollowfibre	Envelope	1360 g	+20°C ♀: +9°C ♂: +4°C -10°C	2
Astro Plus	190T soft handle polyester	Soft polycotton	1x250 g/m <sup>2</sup> Hollowfibre	Envelope	1450 g	+20°C ♀: +8°C ♂: +3°C -12°C	2
Devil 200	190T soft handle polyester	Soft polycotton	2x100 g/m <sup>2</sup> Hollowfibre	Mummy	1400 g	+20°C ♀: +9°C ♂: +5°C -10°C	2
Devil 300	190T soft handle polyester	Soft polycotton	2x150 g/m <sup>2</sup> Hollowfibre	Mummy	1700 g	+15°C ♀: +3°C ♂: -2°C -19°C	2-3
Devil 400	190T soft handle polyester	Soft polycotton	2x200 g/m <sup>2</sup> Hollowfibre	Mummy	2000 g	+12°C ♀: -1°C ♂: -7°C -25°C	3
Lite 900	190T soft handle polyester ripstop	Micro polyester	1x100 g/m <sup>2</sup> Microfibre	Mummy	760 g	+22°C ♀: +13°C ♂: +9°C -4°C	2
Lite 1100	190T soft handle polyester ripstop	Micro polyester	1x150 g/m <sup>2</sup> Microfibre	Mummy	780 g	+21°C ♀: +10°C ♂: +6°C -8°C	2
Atlanta	Soft polycotton	Soft polycotton	1x250 g/m <sup>2</sup> Hollowfibre	Envelope	1450 g	+22°C ♀: +13°C ♂: +9°C -4°C	2
Atlanta Plus	Soft polycotton	Soft polycotton	1x250 g/m <sup>2</sup> Hollowfibre	Envelope	1750 g	+22°C ♀: +12°C ♂: +8°C -5°C	2
Atlanta Deluxe	Soft polycotton	Soft polycotton	1x250 g/m <sup>2</sup> Hollowfibre	Envelope	1850 g	+18°C ♀: +6°C ♂: +1°C -14°C	2-3
Atlanta Double	Soft polycotton	Soft polycotton	1x250 g/m <sup>2</sup> Hollowfibre	Envelope	3000 g	+21°C ♀: +11°C ♂: +7°C -6°C	2

### COMIC - CHILLI PEPPER

Item no.: 340600  
 Size: 190 x 75 cm  
 Body length: 190 cm  
 Shell: 190T soft handle polyester  
 Zipper: Two way open end  
 Construction: Single layer, autostitching  
 Filling: 1 x 250 g/m<sup>2</sup> Hollowfibre  
 Lining: Soft polycotton  
 Weight: App. 1250 gram  
 Pack size: 37 x 21 cm  
 Features: Duvet style, Full length zip baffle



+20°C ♀: +9°C ♂: +5°C -6°C



### COMIC - HORIZON BLUE

Item no.: 340601  
 Size: 190 x 75 cm  
 Body length: 190 cm  
 Shell: 190T soft handle polyester  
 Zipper: Two way open end  
 Construction: Single layer, autostitching  
 Filling: 1 x 250 g/m<sup>2</sup> Hollowfibre  
 Lining: Soft polycotton  
 Weight: App. 1250 gram  
 Pack size: 37 x 21 cm  
 Features: Duvet style, Full length zip baffle



+20°C ♀: +9°C ♂: +5°C -6°C



Bright and cheery, these bags are sure to liven up the morning after the night before. A vary reasonably priced sleeping bag available in colours to suit your mood. Perfect for that festival or sleepover.



### COMIC - MACAW GREEN

Item no.: 340602  
 Size: 190 x 75 cm  
 Body length: 190 cm  
 Shell: 190T soft handle polyester  
 Zipper: Two way open end  
 Construction: Single layer, autostitching  
 Filling: 1 x 250 g/m<sup>2</sup> Hollowfibre  
 Lining: Soft polycotton  
 Weight: App. 1250 gram  
 Pack size: 37 x 21 cm  
 Features: Duvet style, Full length zip baffle



2 season

+20°C ♀: +9°C ♂: +5°C -6°C



### COMIC - VIOLET

Item no.: 340603  
 Size: 190 x 75 cm  
 Body length: 190 cm  
 Shell: 190T soft handle polyester  
 Zipper: Two way open end  
 Construction: Single layer, autostitching  
 Filling: 1 x 250 g/m<sup>2</sup> Hollowfibre  
 Lining: Soft polycotton  
 Weight: App. 1250 gram  
 Pack size: 37 x 21 cm  
 Features: Duvet style, Full length zip baffle



2 season

+20°C ♀: +9°C ♂: +5°C -6°C



Bright and cheery, these bags are sure to liven up the morning after the night before. A vary reasonably priced sleeping bag available in colours to suit your mood. Perfect for that festival or sleepover.



single layer  
construction



single hole  
hollow fibre



regular  
stuff sac



zip  
together

### COSMOS 150

Item no.: 340613  
 Size: 210 x 75 x 50 cm  
 Body length: 190 cm  
 Shell: 190T soft handle polyester  
 Zipper: Two way open end, autolock  
 Construction: Single layer, autostitching  
 Filling: 1 x 150 g/m<sup>2</sup> Hollowfibre  
 Lining: Soft polycotton  
 Weight: App. 850 gram  
 Pack size: 36 x 21 cm  
 Features: Ridge hood, full length zip baffle and anti-snap guard



1-2 season

+22°C ♀: +12°C ♂: +8°C -5°C



### COSMOS 250

Item no.: 340614  
 Size: 210 x 75 x 50 cm  
 Body length: 190 cm  
 Shell: 190T soft handle polyester  
 Zipper: Two way open end, autolock  
 Construction: Single layer, autostitching  
 Filling: 1 x 250 g/m<sup>2</sup> Hollowfibre  
 Lining: Soft polycotton  
 Weight: App. 1100 gram  
 Pack size: 37 x 23 cm  
 Features: Ridge hood, full length zip baffle and anti-snap guard



2 season

+20°C ♀: +10°C ♂: +5°C -9°C



Great value, loft and warmth with soft and subtle fabrics make this range of mummy shaped rectangle bags a must have for any camping trip. Easy to clean or wash and with hollowfibre lining make the range highly suitable for a variety of uses from sleepovers to camping adventures.



single layer  
construction



single hole  
hollow fibre



regular  
stuff sac



zip  
together

### COSMOS 350

Item no.: 340615  
 Size: 210 x 75 x 50 cm  
 Body length: 190 cm  
 Shell: 190T soft handle polyester  
 Zipper: Two way open end, autolock  
 Construction: Single layer, autostitching  
 Filling: 1 x 350 g/m<sup>2</sup> Hollowfibre  
 Lining: Soft polycotton  
 Weight: App. 1100 gram  
 Pack size: 39 x 25 cm  
 Features: Ridge hood, full length zip baffle and anti-snap guard



+17°C ♀: +6°C ♂: +1°C -14°C



### COSMOS PLUS

Item no.: 340616  
 Size: 220 x 85 x 55 cm  
 Body length: 200 cm  
 Shell: 190T soft handle polyester  
 Zipper: Two way open end, autolock  
 Construction: Single layer, autostitching  
 Filling: 1 x 250 g/m<sup>2</sup> Hollowfibre  
 Lining: Soft polycotton  
 Weight: App. 1600 gram  
 Pack size: 42 x 27 cm  
 Features: Ridge hood, full length zip baffle and anti-snap guard



+18°C ♀: +7°C ♂: +2°C -13°C



Great value, loft and warmth with soft and subtle fabrics make this range of mummy shaped rectangle bags a must have for any camping trip. Easy to clean or wash and with hollowfibre lining make the range highly suitable for a variety of uses from sleepovers to camping adventures.

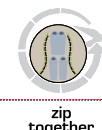

### ASTRO - GREEN

Item no.: 340617  
 Size: 190 x 75 cm  
 Body length: 190 cm  
 Shell: 190T soft handle polyester  
 Zipper: Two way open end, autolock  
 Construction: Single layer, autostitching  
 Filling: 1 x 250 g/m<sup>2</sup> Hollowfibre  
 Lining: Soft polycotton  
 Weight: App. 1350 gram  
 Pack size: 37 x 21 cm  
 Features: Duvet style, full length zip baffle and anti-snag guard



2 season

+20°C ♀: +9°C ♂: +4°C -10°C



### ASTRO - NAVY

Item no.: 340618  
 Size: 190 x 75 cm  
 Body length: 190 cm  
 Shell: 190T soft handle polyester  
 Zipper: Two way open end, autolock  
 Construction: Single layer, autostitching  
 Filling: 1 x 250 g/m<sup>2</sup> Hollowfibre  
 Lining: Soft polycotton  
 Weight: App. 1350 gram  
 Pack size: 37 x 21 cm  
 Features: Duvet style, full length zip baffle and anti-snag guard



2 season

+20°C ♀: +9°C ♂: +4°C -10°C



### ASTRO - PLUS

Item no.: 340619  
 Size: 200 x 85 cm  
 Body length: 200 cm  
 Shell: 190T soft handle polyester  
 Zipper: Two way open end, autolock  
 Construction: Single layer, autostitching  
 Filling: 1 x 250 g/m<sup>2</sup> Hollowfibre  
 Lining: Soft polycotton  
 Weight: App. 1450 gram  
 Pack size: 39 x 24 cm  
 Features: Duvet style, full length zip baffle and anti-snag guard



2 season

+20°C ♀: +8°C ♂: +3°C -12°C



Great value, loft and warmth with soft and subtle fabrics make this range of rectangle bags a must have for any camping trip. Easy to clean or wash with hollowfibre lining make the range highly suitable for a variety of uses from sleepovers to camping adventures.



single layer construction



single hole hollow fibre



regular stuff sac



zip together



**DEVIL 200**

Item no.: 340635  
 Size: 210 x 80 x 50 cm  
 Body length: 190 cm  
 Shell: 190T soft handle polyester  
 Zipper: Two way open end, autolock  
 Construction: Double layer, off-set stitching  
 Filling: 2 x 100 g/m<sup>2</sup> Hollowfibre  
 Lining: Soft polycotton  
 Weight: App. 1400 gram  
 Pack size: 39 x 22 cm  
 Features: Ridge hood, neck baffle, full length zip baffle, pocket and anti-snag guard



+20°C ♀: +9°C ♂: +5°C -10°C



**DEVIL 300**

Item no.: 340636  
 Size: 210 x 80 x 50 cm  
 Body length: 190 cm  
 Shell: 190T soft handle polyester  
 Zipper: Two way open end, autolock  
 Construction: Double layer, off-set stitching  
 Filling: 2 x 150 g/m<sup>2</sup> Hollowfibre  
 Lining: Soft polycotton  
 Weight: App. 1700 gram  
 Pack size: 45 x 24 cm  
 Features: Ridge hood, neck baffle, full length zip baffle, pocket and anti-snag guard



+15°C ♀: +3°C ♂: -2°C -19°C



**DEVIL 400**

Item no.: 340637  
 Size: 210 x 80 x 50 cm  
 Body length: 190 cm  
 Shell: 190T soft handle polyester  
 Zipper: Two way open end, autolock  
 Construction: Double layer, off-set stitching  
 Filling: 2 x 200 g/m<sup>2</sup> Hollowfibre  
 Lining: Soft polycotton  
 Weight: App. 2000 gram  
 Pack size: 46 x 26 cm  
 Features: Ridge hood, neck baffle, full length zip baffle, pocket and anti-snag guard



+12°C ♀: -1°C ♂: -7°C -25°C



More loft, more warmth, more comfort; this range of stylish bags is designed to perform. Double layer construction, hollowfibre filling, off-set stitching, oversized draft baffles all offer effective heat retention. The bags are designed to be comfortable and perform. Ideal if you are searching for a higher performing sleeping bag.

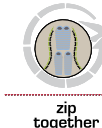
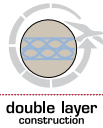

**LITE 900**

Item no.: 340638  
 Size: 210 x 80 x 50 cm  
 Body length: 190 cm  
 Shell: Soft handle polyester ripstop  
 Zipper: Two way open end, autolock  
 Construction: Single layer  
 Filling: 1 x 100 g/m<sup>2</sup> Micro polyester fibre  
 Lining: Micro polyester  
 Weight: App. 760 gram  
 Pack size: 29 x 16 cm  
 Features: Ridge hood, neck baffle, full length zip baffle, pocket and anti-snap guard



+22°C ♀: +13°C ♂: +9°C -4°C



**LITE 1100**

Item no.: 340639  
 Size: 210 x 80 x 50 cm  
 Body length: 190 cm  
 Shell: Soft handle polyester ripstop  
 Zipper: Two way open end, autolock  
 Construction: Single layer  
 Filling: 1 x 150 g/m<sup>2</sup> Micro polyester fibre  
 Lining: Micro polyester  
 Weight: App. 780 gram  
 Pack size: 34 x 19 cm  
 Features: Ridge hood, neck baffle, full length zip baffle, pocket and anti-snap guard



+21°C ♀: +10°C ♂: +6°C -8°C



A combination of lightweight fabrics, performance insulation and compact pack size make this range a 'must have' for adventure travelling and backpacking.

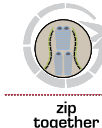
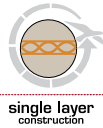

**ATLANTA**

Item no.: 340680  
 Size: 190 x 80 cm  
 Body length: 190 cm  
 Shell: Soft polycotton  
 Zipper: Two way open end, autolock  
 Construction: Single layer, autostitching  
 Filling: 1 x 250 g/m<sup>2</sup> Hollowfibre  
 Lining: Soft polycotton  
 Weight: App. 1450 gram  
 Pack size: 43 x 35 x 15 cm  
 Features: Duvet style, full length zip baffle and anti-snap guard



+22°C ♀ +13°C ♂ +9°C -4°C



**ATLANTA PLUS**

Item no.: 340683  
 Size: 200 x 90 cm  
 Body length: 200 cm  
 Shell: Soft polycotton  
 Zipper: Two way open end, autolock  
 Construction: Single layer, autostitching  
 Filling: 1 x 250 g/m<sup>2</sup> Hollowfibre  
 Lining: Soft polycotton  
 Weight: App. 1750 gram  
 Pack size: 46 x 38 x 15 cm  
 Features: Duvet style, full length zip baffle, pocket and anti-snap guard



+22°C ♀ +12°C ♂ +8°C -5°C



Great rectangle sleeping bags for the family camper in a variety of shapes and sizes. Each one can be opened out duvet style and the double can also be converted into 2 singles. Ideal for family camping and able to keep you warm throughout the summer camping months.

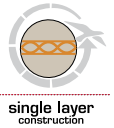

### ATLANTA DELUXE

Item no.: 340684  
 Size: 225 x 90 cm  
 Body length: 200 cm  
 Shell: Soft polycotton  
 Zipper: Two way open end, autolock  
 Construction: Single layer, autostitching  
 Filling: 1 x 250 g/m<sup>2</sup> Hollowfibre  
 Lining: Soft polycotton  
 Weight: App. 1850 gram  
 Pack size: 46 x 38 x 15 cm  
 Features: Duvet style, full length zip baffle, pocket and anti-s snag guard



2-3 season

+18°C ♀: +6°C ♂: +1°C -14°C



### ATLANTA DOUBLE

Item no.: 340685  
 Size: 210 x 150 cm  
 Body length: 210 cm  
 Shell: Soft polycotton  
 Zipper: Two way open end, autolock  
 Construction: Single layer, autostitching  
 Filling: 1 x 250 g/m<sup>2</sup> Hollowfibre  
 Lining: Soft polycotton  
 Weight: App. 3000 gram  
 Pack size: 52 x 42 x 19 cm  
 Features: Duvet style, full length zip baffle, pocket and anti-s snag guard



2 season

+21°C ♀: +11°C ♂: +7°C -6°C



Great rectangle sleeping bags for the family camper in a variety of shapes and sizes. Each one can be opened out duvet style and the double can also be converted into 2 singles. Ideal for family camping and able to keep you warm throughout the summer camping months.



single layer  
construction



single hole  
hollow fibre



regular  
stuff sac

**LITE MAT - SHORT**

Item no.: 390843  
Fabric: Polyester PVC coated  
Size: 122 x 51 x 2.5 cm  
Pack size: 54 x 9 cm  
Weight: 700 g

**LITE MAT -LONG**

Item no.: 390844  
Fabric: Polyester PVC coated  
Size: 183 x 51 x 2.5 cm  
Pack size: 54 x 11 cm  
Weight: 980 g

**BASE MAT - SINGLE**

Item no.: 390845  
Fabric: Polyester Pongee  
Size: 188 x 51 x 3.5 cm  
Pack size: 54 x 14 cm  
Weight: 1300 g

**BASE MAT - TWIN**

Item no.: 390846  
Fabric: Polyester Pongee  
Size: 188 x 130 x 3.5 cm  
Pack size: 66 x 18 cm  
Weight: 3400 g

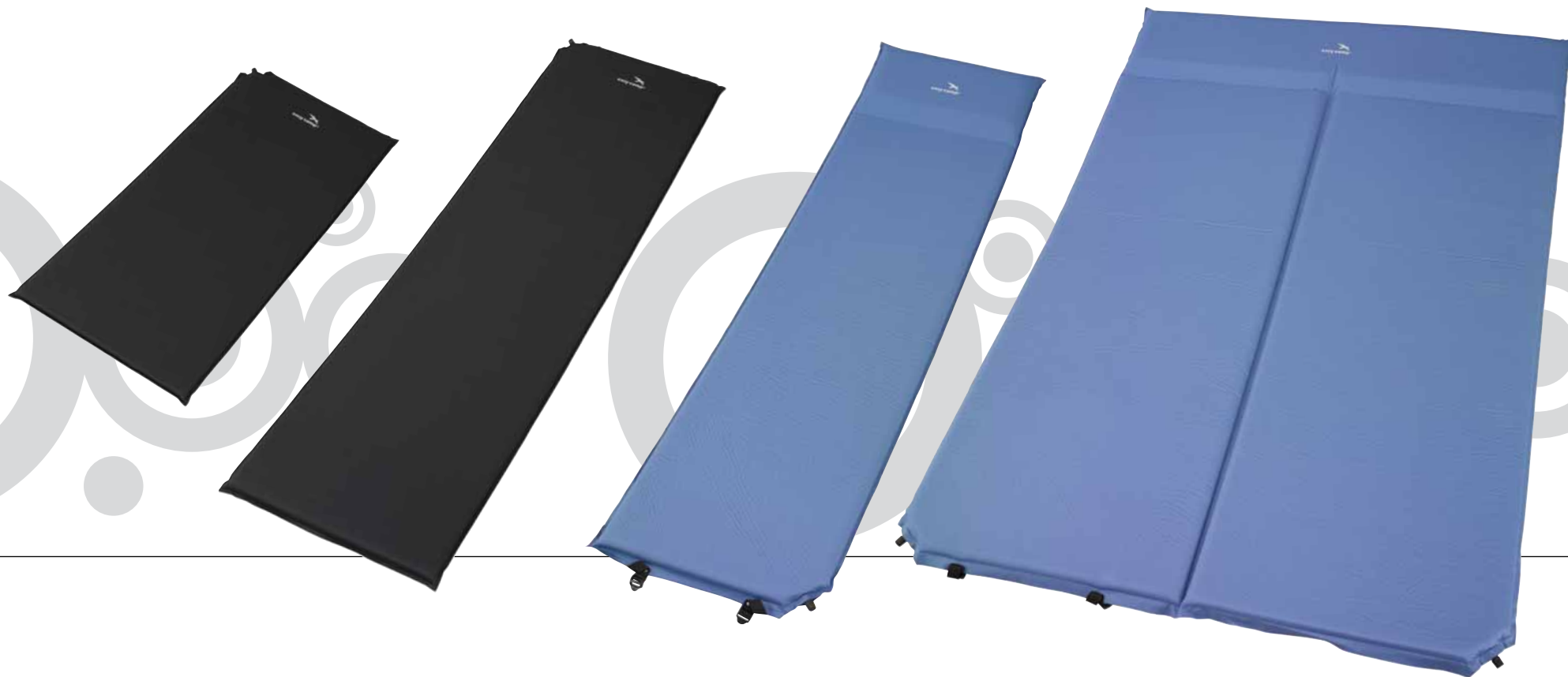

The Easy Camp self-inflating mats come in a variety of sizes and colours suitable for many end uses. Choose from bright colours, lightweight or comfort there is something for everyone. The range features open cell foam construction for maximum comfort as well as our Easy Valve system to allow maximum airflow for inflating and deflating. Stuff bag included.

**HEXA MAT - MULTI PACK**

Item no.: 390839  
Fabric: Polyester PVC coated  
Size: 185 x 45 cm  
Pack size: 26.5 x 16.5 x 5.5 cm  
Weight: 600 g  
Features: Built-in pump, one valve for inflating, lightweight, stuff bag



A new concept for Easy Camp marrying the benefits of self-inflating with the comfort of airbeds. The Hexamat has a built-in footpump and large air intake one-way valve combined with a soft and light outer surface resulting in a very lightweight, easy to inflate comfortable air mattress. Ideal for camping, staying at friends or going to festivals.

**FLOCK AIRBED SINGLE**

Item no.: 390848  
Fabric: Flocked PVC  
Size: 184 x 74 x 13 cm  
Features: I-Beam construction  
Soft velour top  
Double function valve for  
easy in/deflate

**FLOCK AIRBED DOUBLE**

Item no.: 390849  
Fabric: Flocked PVC  
Size: 184 x 137 x 13 cm  
Features: I-Beam construction  
Soft velour top  
Double function valve for  
easy in/deflate



Now added to the range to complement our family tents, the airbeds can be used both indoor and outdoor. Soft flock top surface for maximum comfort allowing for a good nights sleep.

### TRAVEL SHEET MUMMY

Item no.: 340693  
Fabric: Polycotton  
Open size: 210 x 75 x 50 cm  
Weight: 240 g  
Pack size: 15 x 7 cm  
Pieces per carton 10

### TRAVEL SHEET RECTANGLE

Item no.: 340694  
Fabric: Polycotton  
Open size: 200 x 75 cm  
Weight: 290 g  
Pack size: 15 x 10 cm  
Pieces per carton 10

### TRAVEL SHEET - YHA

Item no.: 340695  
Fabric: Polycotton  
Open size: 200 x 70 cm  
Weight: 280 g  
Pack size: 15 x 10 cm  
Pieces per carton 10

### TRAVEL SHEET ULTRALIGHT

Item no.: 340696  
Fabric: Micro Polyester  
Open size: 210 x 75 x 50 cm  
Weight: 200 g  
Pack size: 13 x 7 cm  
Pieces per carton 10





Just relax and enjoy.... That is the Easy Camp RELAX concept! Within this concept you will find all that is needed for an enjoyable and successful camping trip. There is folding furniture which is easy to carry and folds to a small pack size for easy storage and transport. Also, there is a more traditional and very comfortable range of camping furniture at affordable prices. The RELAX concept has cupboards, tables and kitchen tables that will enhance your camping trip by adding easy storage solutions for your holiday home.





This range has been very successful for camping enthusiasts and is available in two colours – a spring green and a light blue. This range is light to carry and folds down to a small size for convenience and of course is comfortable in use.

**JUNIOR CHAIR**

Item no.: 670310  
 Open size: W 37 x D 36 x H 59 cm  
 Weight: App. 1.8 kg  
 Max load: 50 kg

**ARM CHAIR**

Item no.: 670312  
 Open size: W 82 x D 52 x H 80 cm  
 Weight: App. 4.2 kg  
 Max load: 100 kg

**FOLDING CHAIR**

Item no.: 670311  
 Open size: W 49 x D 49 x H 73 cm  
 Weight: App. 2.8 kg  
 Max load: 75 kg

**HI-BACK CHAIR**

Item no.: 670314  
 Open size: W 89 x D 152 x H 102 cm  
 Weight: App. 4.9 kg  
 Max load: 100 kg



**CAMP CHAIR**

Item no.: 670317  
 Open size: W 68 x D 61 x H 95 cm  
 Weight: App. 5.3 kg  
 Max load: 100 kg

**DIRECTOR CHAIR**

Item no.: 670318  
 Open size: W 48 x D 49 x H 82 cm  
 Weight: App. 3.4 kg  
 Max load: 100 kg

**CROSS CHAIR**

Item no.: 670319  
 Open size: W 55 x D 75 x H 100 cm  
 Weight: App. 4.4 kg  
 Max load: 100 kg

**RECLINING CHAIR**

Item no.: 670313  
 Open size: W 93 x D 92 x  
 H 130 cm  
 Weight: App. 6.1 kg  
 Max load: 100 kg



**CAMP TABLE**

Item no.: 670315  
Open size: W 49 x D 49 x H 47 cm  
Weight: App. 2.3 kg

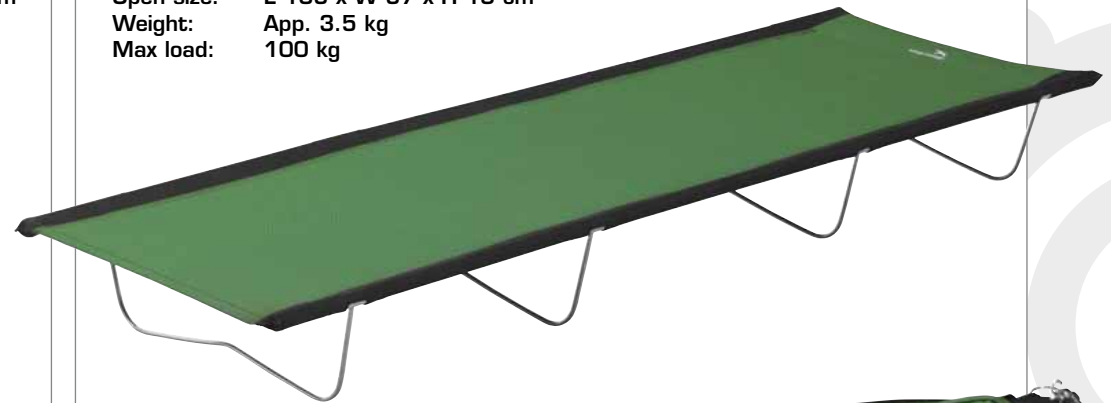
**CAMP BED**

Item no.: 670322  
Open size: L 185 x W 57 x H 19 cm  
Weight: App. 3.5 kg  
Max load: 100 kg

**FOLDING BED**

Item no.: 670316  
Open size: L 190 x W 69 x H 35 cm  
Weight: App. 8.1 kg  
Max load: 100 kg

**HAMMOCK**

Item no.: 670321  
Open size: L 277 x W 76 x H 79 cm  
Weight: App. 10.5 kg  
Max load: 100 kg



**JUNIOR CHAIR**

Item no.: 670340  
 Open size: W 37 x D 36 x H 59 cm  
 Weight: App. 1.8 kg  
 Max load: 50 kg

**ARM CHAIR**

Item no.: 670342  
 Open size: W 82 x D 52 x H 80 cm  
 Weight: App. 4.2  
 Max load: 100 kg

**FOLDING CHAIR**

Item no.: 670341  
 Open size: W 49 x D 49 x H 73 cm  
 Weight: App. 2.8 kg  
 Max load: 75 kg

**HI-BACK CHAIR**

Item no.: 670344  
 Open size: W 89 x D 152 x H 102 cm  
 Weight: App. 4.9 kg  
 Max load: 100 kg



**CAMP CHAIR**

Item no.: 670347  
 Open size: W 68 x D 61 x H 95 cm  
 Weight: App. 5.3 kg  
 Max load: 100 kg



**DIRECTOR CHAIR**

Item no.: 670348  
 Open size: W 48 x D 49 x H 82 cm  
 Weight: App. 3.4 kg  
 Max load: 100 kg



**CROSS CHAIR**

Item no.: 670349  
 Open size: W 55 x D 75 x H 100 cm  
 Weight: App. 4.4 kg  
 Max load: 100 kg

**RECLINING CHAIR**

Item no.: 670343  
 Open size: W 93 x D 92 x H 130 cm  
 Weight: App. 6.1 kg  
 Max load: 100 kg



**CAMP TABLE**

Item no.: 670345  
 Open size: W 49 x D 49 x H 47 cm  
 Weight: App. 2.3 kg

**CAMP BED**

Item no.: 670352  
 Open size: L 185 x W 57 x H 19 cm  
 Weight: App. 3.5 kg  
 Max load: 100 kg

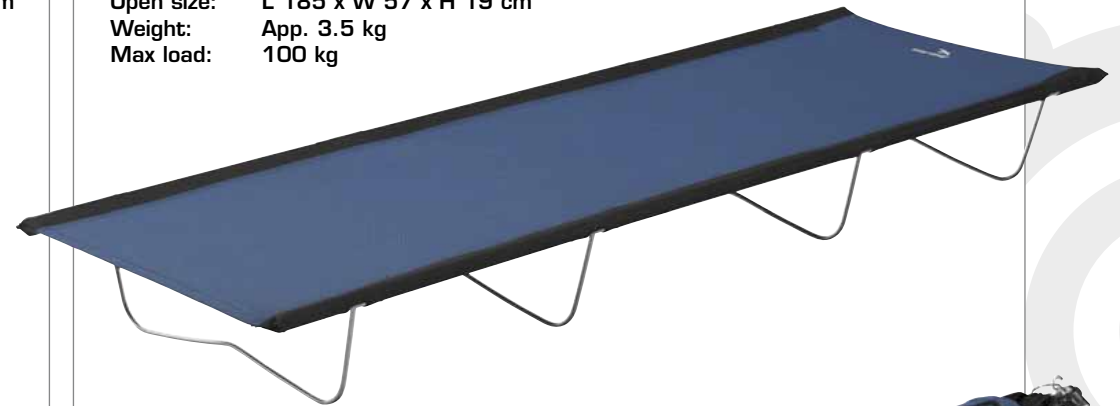
**FOLDING BED**

Item no.: 670346  
 Open size: L 190 x W 69 x H 35 cm  
 Weight: App. 8.1 kg  
 Max load: 100 kg

**HAMMOCK**

Item no.: 670351  
 Open size: L 277 x W 76 x H 79 cm  
 Weight: App. 10.5 kg  
 Max load: 100 kg



A very well priced comfortable Camping Furniture made in a lightweight alloy making them attractive to the eye and comfortable in use. Great for campers and caravanners alike.

**ANTIBES**

Item no.: 670540  
 Open size: W 36 x D 32 x H 45 cm  
 Weight: App. 1.1 kg

**MONACO**

Item no.: 670543  
 Open size: W 47 x D 66 x H 112 cm  
 Weight: App. 3.9 kg  
 Features: 5 position chair

**CANNES**

Item no.: 670541  
 Open size: W 41 x D 37 x H 67 cm  
 Weight: App. 1.6 kg

**NICE**

Item no.: 670542  
 Open size: W 45 x D 60 x H 100 cm  
 Weight: App. 3.7 kg  
 Features: 5 position chair

**LYON**

Item no.: 670545  
 Open size: W 58 x D 188 x H 29 cm  
 Weight: App. 5.0 kg  
 Features: 4 position bed

**LILLE**

Item no.: 670546  
 Open size: W 46 x D 75 x H 42 cm  
 Weight: App. 1.0 kg

**PILLOW**

Item no.: 670548  
 Open size: W 47 x D 6 x H 17 cm  
 Weight: 185 g

**MARSEILLE**

Item no.: 670544  
 Open size: W 59 x D 70 x H 113 cm  
 Weight: App. 4.5 kg  
 Features: 5 position chair

**STRASBOURG**

Item no.: 670547  
 Open size: W 58 x D 62 x H 110 cm  
 Weight: App. 3.3 kg  
 Features: 5 position chair



A new range of camping cupboards that will enhance your trip by adding easy storage solutions for your holiday home. Available in a variety of sizes with full zip mesh doors and multiple shelves for convenience - stay organised while you are away.

**MATAR**

Item no.: 670179  
 Fabric: Polyester  
 Open size: W 61 x D 48 x H 105 cm  
 Pack size: W 63 x D 52 x H 11 cm  
 Weight: App. 6.4 kg

**TABIT**

Item no.: 670180  
 Fabric: Polyester  
 Open size: W 61 x D 48 x H 140 cm  
 Pack size: W 63 x D 52 x H 13 cm  
 Weight: App. 7.6 kg

**SUBRA**

Item no.: 670181  
 Fabric: Polyester  
 Open size: W 80 x D 48 x H 84 cm  
 Pack size: W 83 x D 52 x H 11 cm  
 Weight: App. 7.9 kg



Food we all need and especially on a holiday. To do a good cooking you need the perfect kitchen table. In this years range we have a variety of tables with features such as steel frames, storage shelves, zip covers and small pack sizes.

**BEAUVAIS**

Item no.: 670190  
Open size: W 67 x D 48 x H 79 cm  
Pack size: W 75 x D 45 x H 10 cm  
Weight: App. 5.9 kg

**AVIGNON**

Item no.: 670191  
Open size: W 66 / 58 x D 48 x H 79 cm  
Pack size: W 75 x D 48 x H 7 cm  
Weight: App. 8.1 kg



Our successful range of tables is now expanded for the new season continue, featuring a new more stable aluminium tables as a well as durable resin top table. Also now included is a small table ideal for food preparation while backpacking. All models include a carrier bag for easy storage.



**CALAIS**  
 Item no.: 670195  
 Open size: W 70 x D 70 x H 70 cm  
 Max load: 30 kg  
 Pack size: 70 x 12 cm  
 Weight: App. 2.9 kg



**RENNES S**  
 Item no.: 670198  
 Open size: W 70 x D 70 x H 70 cm  
 Max load: 30 kg  
 Pack size: 70 x 12 cm  
 Weight: App. 3.0 kg



**RENNES L**  
 Item no.: 670197  
 Open size: W 110 x D 70 x H 70 cm  
 Max load: 30 kg  
 Pack size: 75 x 20 x 17 cm  
 Weight: App. 5.1 kg



**NIMES**  
 Item no.: 670202  
 Open size: W 120 x D 70 x H 70 cm  
 Max load: 30 kg  
 Pack size: 123 x 18 x 13 cm  
 Weight: App. 5.6 kg

**BORDEAUX**

Item no.: 670414  
 Open size: W 100 x D 68 x H 65-82 cm  
 Pack size: W 100 x D 68 x H 5 cm  
 Weight: App. 8.6 kg  
 Features: Adjustable height

**NANTES**

Item no.: 670199  
 Open size: W 120 x D 60 x H 70 cm  
 Max load: 30 kg  
 Pack size: W 64 x D 8.5 x H 63 cm  
 Weight: App. 4.5 kg

**VANNES**

Item no.: 670201  
 Open size: W 80 x D 60 x H 50/62 cm  
 Max load: 30 kg  
 Pack size: 80 x 60 x 3 cm  
 Weight: App. 3.2 kg

**ANGERS**

Item no.: 670200  
 Open size: W 40 x D 29 x H 16.5 cm  
 Max load: 10 kg  
 Pack size: 41 x 6 x 6 cm  
 Weight: App. 900 g

These portable tables are compact and easy to carry yet very stable when opened. For picnic or camping these tables fulfill your needs for easy comfort.

**PARIS**

Item no.: 670412  
Open size: W 180 x D 82 x H 70 cm (Top: W 98 x D 82)  
Weight: App. 12.5 kg  
Pack size: 82 x 49 x 10 cm  
Feature: Easy to carry

**TOULOUSE**

Item no.: 670410  
Open size: W 136 x D 84 x H 66 cm (Top: W 64 x D 84)  
Weight: App. 6.5 kg  
Pack size: 84 x 32 x 10 cm  
Feature: Easy to carry



**DIJON**

Item no.: 670409  
Open size: Top: W 92.5 x D 120 x H 69 cm  
Bench: W 87 x D 25 x H 40 cm  
Stool: W 34 x D 34.5 x H 41.5 cm  
Weight: App. 12.6 kg  
Pack size: W 92.5 x D 14.5 x H 41.5 cm  
Feature: Easy to carry



Whether commuting on a train, doing the school run or travelling across Europe, there is now an Easy Camp rucsac that is suitable. New models, great styles and attractive colours ensure that, whatever choice is made, it will be stylish and yet take the punishment of everyday use. For easy identification the range is positioned within the broad category themes presented within the sleeping bag and rucsac ranges.

**CARNIVAL** is for being young and having fun. People who have a variety of hobbies from going to festivals, overnight camping with friends, short trips throughout Europe and ultimately enjoying the freedom of the outdoor environment. This range of products are about being attractive, easy to use, simple to understand, modern and inexpensive.

**EXPLORER** is about getting out and seeing the world outside. Weekends near the lakes, biking in the forest parks, sleeping in the valleys. This range of products will do the job without costing the earth. Suitable for those starting out with their camping experiences.

**GO** is about versatility, performance and dependability. A range aimed at regular users looking for that desirable design and specification level, whilst maintaining affordability. Lightweight and compact this range offers a good solutions to those active packing problems.





MAZE & MIST – Bright and cheery, these daysacs are fun and attractive. Very reasonably priced and available in colours to suit your mood. Perfect for that festival or sleepover.

### MAZE

Item no.: 390802 (Chilli Pepper)  
390803 (Horizon Blue)  
390804 (Macaw Green)  
390805 (Violet)

Fabric: 600D polyester

Volume: 15 litre

Weight: 400 g

Features: Mesh back system, front pocket, side compression straps, hip belt, contour padded harness, mesh side pockets, prepared for MP3

Pieces per carton 10



### MIST

Item no.: 390806 (Chilli Pepper)  
390807 (Horizon Blue)  
390808 (Macaw Green)  
390809 (Violet)

Fabric: 600D polyester

Volume: 20 litre

Weight: 600 g

Features: Mesh air back system, front pocket, side compression straps, hip belt, contour padded harness, front drawcord, mesh side pockets, prepared for MP3

Pieces per carton 10

### SUMMIT

A classic pack with an adjustable harness system for a 'one size fits all' solution. Packed with features, yet extremely comfortable; the uses are endless. Easy and quick to adjust for you individual preference, this pack allows loads to be carried in comfort.

### CIRCUIT

Feature filled, yet modern, these packs are perfect for hikers needing a good sized pack that swallows the load but remains comfortable to carry.

### SUMMIT

Item no.: 380696 (50+10 litre)  
380697 (60+10 litre)  
380698 (70+10 litre)

Fabric: 600D polyester

Volume: 50+10 / 60+10 / 70+10 litre

Weight: 2000 / 2200 / 2400 g

Features: Ladder back system, top pockets, divided main compartment, padded hip belt, chest belt, compression straps, contour padded harness, prepared for hydration system, adjustable top lid, rain cover

Pieces per carton 6



### CIRCUIT 40

Item no.: 380703 (Red)  
380704 (Black)

Fabric: 600D / 420D polyester

Volume: 40 litre

Weight: 1100 g

Features: Mesh air back system, divided main compartment, daisy chain, top pocket, divided main compartment, padded hip belt, chest belt, compression straps, side pockets, contour padded harness, prepared for hydration system, elasticated drawcord on top, rain cover

Pieces per carton 6

### TRAVEL

A range of specific travel bags for use around the world – large zip opening, internal compartments, hide away harness and zip off daysacs make these items practical and desirable.

### ACTION

An action pack for fast moving activities with plenty of storage pockets and enough room for spare kit.

### TITAN

Built with ventilation in mind, the fitted back system uses suspended mesh to allow uninhibited air-flow around the back, allowing a more comfortable load carry.

### ACTION

Item no.: 390771 (Red)  
390772 (Black)  
Fabric: 600D polyester/  
420D diamant ripstop polyester  
Volume: 7 litre  
Weight: 500 g  
Features: Mesh air back system, helmet front pocket, 2 front pockets, hip belt, chest belt, side compression straps, contour padded harness, prepared for hydration

Pieces per carton 10



### TRAVEL

Item no.: 390766 (Travel 60+10)  
390767 (Travel 70+10)  
Fabric: 600D polyester  
Volume: 60+10 / 70+10 litre  
Weight: 2900 / 3100 g  
Features: Mesh back system, detachable daypack, divided main compartment, daisy chain, padded hip belt, shoulder strap, side compression straps, contour padded harness, rain cover

Pieces per carton 6



### TITAN

Item no.: 390789 (Grey)  
390790 (Blue)  
390791 (Green)  
Fabric: 600D ripstop polyester  
Volume: 23 litre  
Weight: 500 g  
Features: Mesh air back system, front pocket with organizer, walking pole attachment, chest belt, contour padded harness, prepared for hydration

Pieces per carton 10



**MONTANA FLOWER**

Item no.: 390810 (Lime)  
 390811 (Red)  
 390812 (Black)

Fabric: 600D polyester

Details: S-shaped shoulder straps  
 Detachable bottle cooler  
 11.5 L cool compartment  
 Front pocket

Weight: App. 2 kg

Contents: 4 x forks, knives, spoons, glasses  
 and plates. Breadboard, removable  
 bottle cooler, corkscrew



**CHAIR FLOWER**

Item no.: 390820 (Lime)  
 390821 (Red)  
 390822 (Black)

Fabric: 1200D Polyester

Open size: W 40 x D 42 x H 40 cm

Weight: App. 800 g

Max load: 100 kg

Features: Practical carrier handle  
 Shoulder straps  
 Pocket  
 Adjustable side straps

**BASKET FLOWER**

Item no.: 390830 (Lime)  
 390831 (Red)  
 390832 (Black)

Fabric: 600D Polyester

Open size: W 25 x D 50 x H 29 cm

Weight: App. 1.3 kg

Features: Handy folding basket with alloy  
 frame and comfortable handle.  
 Including zip side pocket.





Specifically selected, Easy Camp are now introducing a new range of accessories to complement the comprehensive camping offer that Easy Camp is known for. The items have been selected to offer flexible solutions and sensible prices for the many requirements of camping outdoors.

A range of lanterns to use on the darkest nights, a large choice of cook sets to suit all requirements, kettles that would look good on any old stove, tent maintenance accessories for all those unexpected surprises – a full compliment of accessories to choose from.



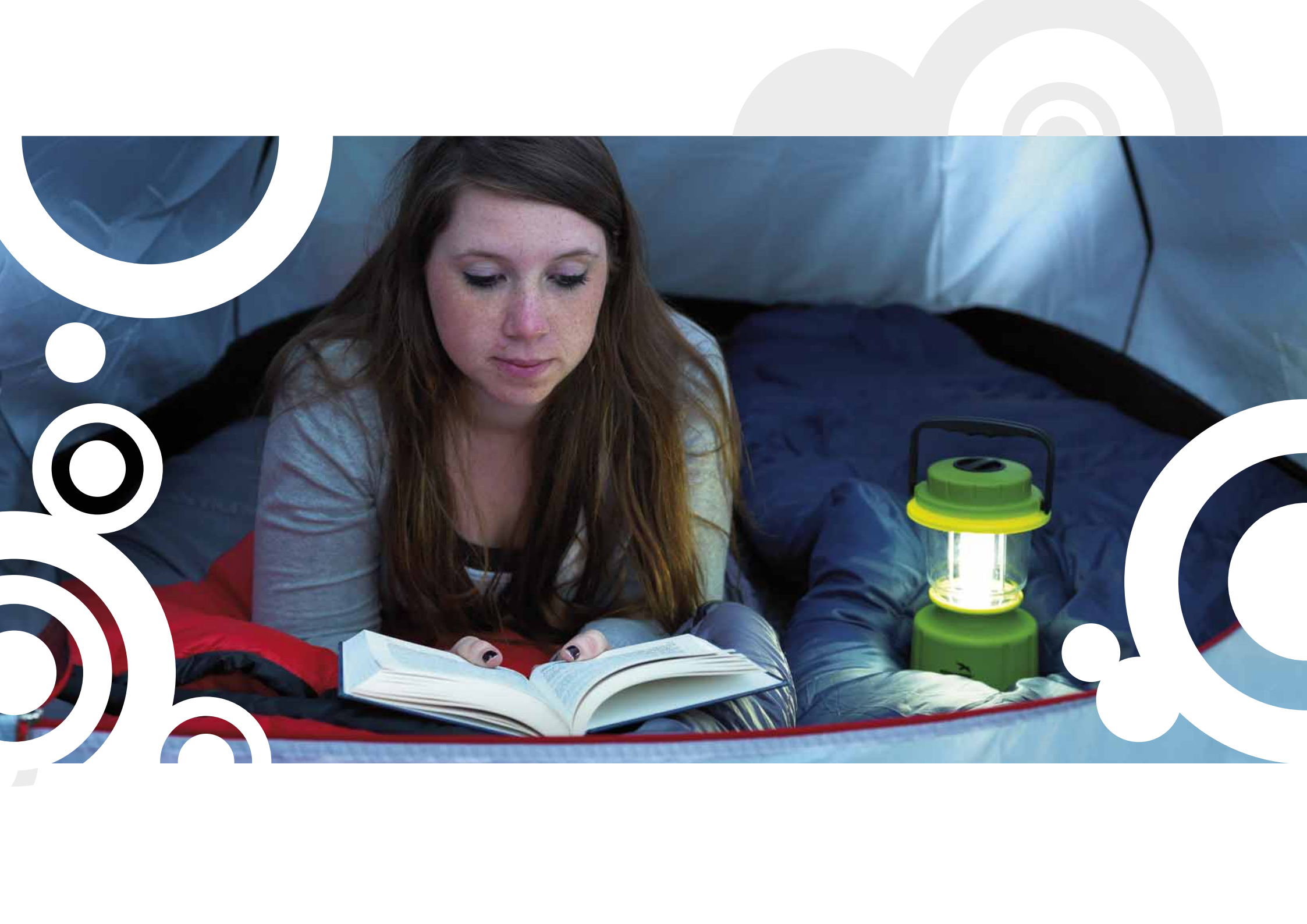

### WHISTLE KETTLE 2.0L - MULTI PACK

Item no.: 580082  
 Material: Stainless Steel  
 Colours: Red, blue, lime and polish  
 Volume: 2.0 litre  
 Features: Whistling  
 Heat resistant handle  
 Button to open/close spout  
 MOQ: Inner box 4  
 Pieces per carton 8



### COMPACT KETTLE 0.8L

Item no.: 580080  
 Material: Aluminium  
 Volume: 0.8 litre  
 Features: With teaholder  
 Pieces per carton 12



### PRESTIGE KETTLE 1.6L

Item no.: 580083  
 Material: Stainless Steel  
 Volume: 1.6 litre  
 Features: Whistling  
 Heat resistant folding handle  
 Removable lid  
 Pieces per carton 6



### PRESTIGE KETTLE 2.3L

Item no.: 580084  
 Material: Stainless Steel  
 Volume: 2.3 litre  
 Features: Whistling  
 Heat resistant folding handle  
 Removable lid  
 Pieces per carton 6

**ADVENTURE COOK SET - S**

Item no.: 580037

Material: Aluminium

Contents: 2 Pots ( 1.3 / 1.7 litre)

1 Pan 17.5 cm

1 Kettle 0.65 litre

1 Gripper

Pieces per carton 6

**ADVENTURE COOK SET - M**

Item no.: 580038

Material: Aluminium

Contents: 2 Pots (1.7 / 2.2 litre)

1 Pan 19.5 cm

1 Kettle 1.0 litre

1 Gripper

Pieces per carton 6

**ADVENTURE COOK SET - L**

Item no.: 580039

Material: Aluminium

Contents: 2 Pots (2.2 / 3.1 litre)

1 Pan 21.5 cm

1 Kettle 1.0 litre

1 Gripper

Pieces per carton 6



**SOLO COOK SET**

Item no.: 580046

Material: Aluminium Non Stick

Contents: 1 Pot with lid 0.55 litre

1 Bowl 0.4 litre

1 Comfortable folding handle

Pieces per carton 6

**DUO COOK SET**

Item no.: 580047

Material: Aluminium Non Stick

Contents: 1 pot with lid 1.1 litre

1 Bowl 0.4 litre

1 Bowl 0.48 litre

1 Comfortable folding handle

Pieces per carton 6

**TRAIL 3**

Item no.: 580049

Material: Aluminium Non Stick

Contents: 1 Frying pan 17.5 cm

1 Pot 1.5 litre

1 Pot 2.0 litre

1 Gripper

Mesh storage bag

Pieces per carton 6

**TRAIL 4**

Item no.: 580050

Material: Aluminium Non Stick

Contents: 1 Frying pan 19.5 cm

1 Pot 1.5 litre

1 Pot 2.0 litre

1 Gripper

Mesh storage bag

Pieces per carton 6

**TRAIL 5**

Item no.: 580051

Material: Aluminium Non Stick

Contents: 1 Frying pan 21.5 cm

1 Pot 2.0 litre

1 Pot 2.6 litre

1 Gripper

Mesh storage bag

Pieces per carton 6



**ALLOY MESS KIT**

Item no.: 580040  
 Material: Aluminium  
 Contents: 1 Mess Tin 1.3 litre  
 1 Mess Tin 1.0 litre  
 Features: Folding handle  
 Pieces per carton 6

**NON STICK FRYPAN 15 CM**

Item no.: 580060  
 Material: Aluminium Non-Stick  
 Size: Diameter 15 cm  
 Features: Folding handle  
 Pieces per carton 6

**DELUXE NON STICK FRYPAN M**

Item no.: 580064  
 Material: Aluminium Non-Stick  
 Size: Diameter 22 cm  
 Features: Folding handle  
 Pieces per carton 6

**NON STICK MESS KIT**

Item no.: 580059  
 Material: Aluminium  
 Contents: 1 Mess Tin 1.3 litre  
 1 Mess Tin 1.0 litre  
 Features: Folding handle  
 Pieces per carton 6

**NON STICK FRYPAN 19 CM**

Item no.: 580061  
 Material: Aluminium  
 Size: Diameter 19 cm  
 Features: Folding handle  
 Pieces per carton 6

**DELUXE NON STICK FRYPAN L**

Item no.: 580065  
 Material: Aluminium  
 Size: Diameter 27 cm  
 Features: Folding handle  
 Pieces per carton 6

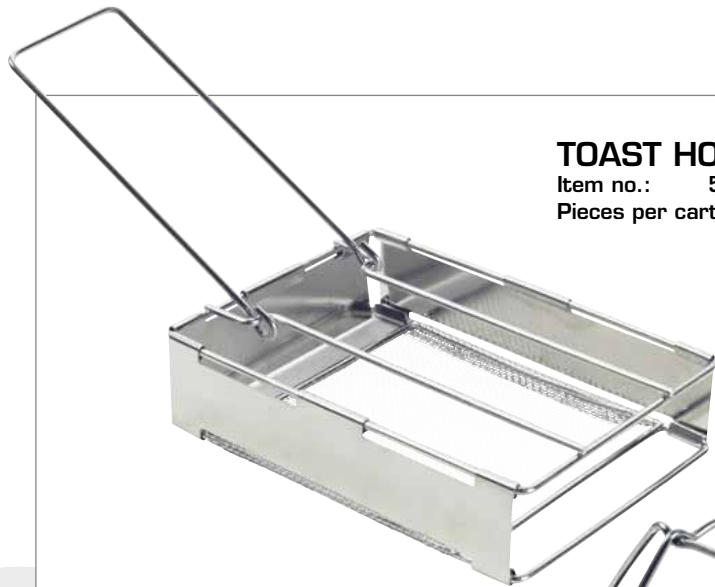

**TOAST HOLDER SINGLE**

Item no.: 580103  
Pieces per carton 10

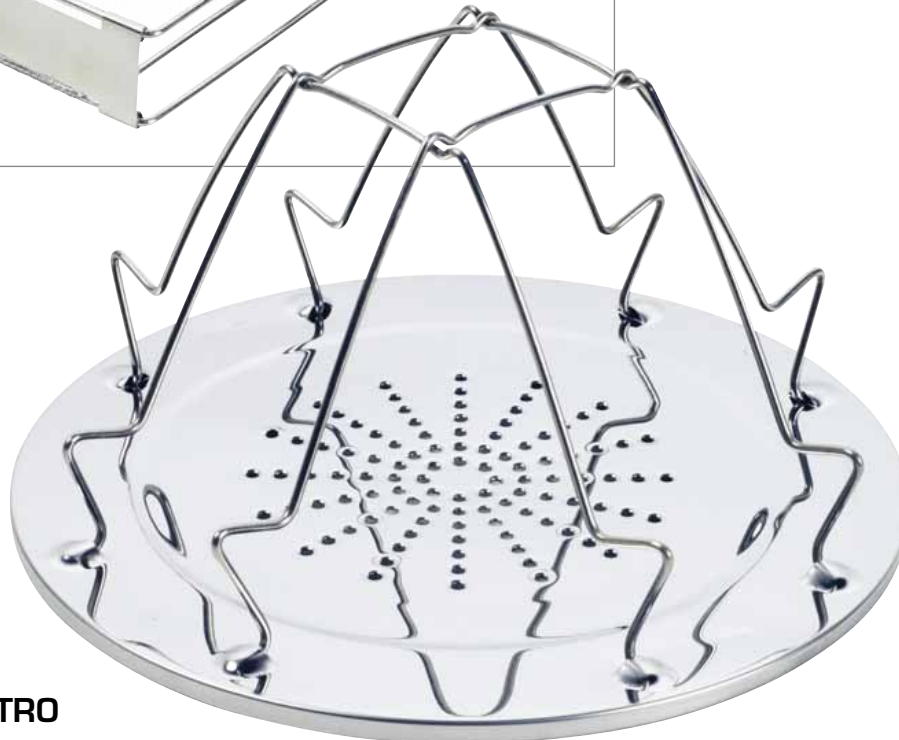
**TOAST HOLDER QUATRO**

Item no.: 580104  
Pieces per carton 10

**CAN OPENER - TWIN PACK**

Item no.: 580101  
Pieces per carton 10

**5 IN 1 OPENER**

Item no.: 580102  
Pieces per carton 10



**FOLDING STOVE**

Item no.: 580097  
Pieces per carton 10



**STOVE WINDSCREEN**

Item no.: 580099  
Pieces per carton 10



**FUEL TABS**

Item no.: 580098  
Pieces per carton 10



**COMBO UTENSIL SET**

Item no.: 580100  
Material: Durable heat resistant nylon  
Pieces per carton 10

**ENAMEL MUG**

Item no.: 580020  
 Volume: 350 ml  
 Pieces per carton 10

**ENAMEL BOWL**

Item no.: 580018  
 Volume: 550 ml  
 Pieces per carton 10

**ENAMEL PLATE**

Item no.: 580016  
 Size: Diameter 26 cm  
 Pieces per carton 10

**MELAMINE SET - 2 PERSON**

Item no.: 580000  
 Contents 6 pcs: 2 Mugs  
                   2 Rice bowls  
                   2 Dinner plates  
 Pieces per carton 6

**MELAMINE SET - 4 PERSON**

Item no.: 580002  
 Contents 12 pcs: 4 Mugs  
                   4 Rice bowls  
                   4 Dinner plates  
 Pieces per carton 6

**CAMPING SET**

Item no.: 580024  
 Contents: 1 Mug 350 ml  
             1 Plate 26 cm  
             1 Bowl 550 ml  
             1 Knife, fork, spoon  
 Pieces per carton 6



**COMPANION MUG**

Item no.: 580004  
Volume: 375 ml  
Pieces per carton 10



**COMPANION BOWL**

Item no.: 580006  
Size: Diameter 18.5 cm  
Pieces per carton 10



**COMPANION SET  
- 4 PERSONS**

Item no.: 580010  
Contents: 4 Knives, forks & spoons  
4 Mugs  
4 Plates  
4 Bowls  
Pieces per carton 6



**BOTTLE 0.5 L  
- MULTI PACK**

Item no.: 580013  
Colours: Red, blue and green  
Volume: 0.5 litre  
MOQ: Inner box 6  
Pieces per carton 12

**COMPANION PLATE**

Item no.: 580005  
Size: Diameter 23.5 cm  
Pieces per carton 10



**COMPANION SALT & PEP-COMPANION  
PER SHAKER**

Item no.: 580007  
Pieces per carton 10



**COMPANION  
CUTLERY SET**

Item no.: 580011  
Contents: 4 knives, forks & spoons  
Pieces per carton 10



**BOTTLE 1.0 L  
- MULTI PACK**

Item no.: 580014  
Colours: Red, blue and green  
Volume: 1.0 litre  
MOQ: Inner box 6  
Pieces per carton 12



**TRAVEL CUTLERY**

Item no.: 580030  
Pieces per carton 10



**FOLDING CUTLERY**

Item no.: 580033  
Pieces per carton 10



**SALT & PEPPER - S  
- MULTI PACK**

Item no.: 580027  
Pieces per carton 36  
MOQ: Inner box 12



**TRAVEL CUTLERY DLX**

Item no.: 580031  
Pieces per carton 10



**FAMILY CUTLERY**

Item no.: 580034  
Pieces per carton 10



**SALT & PEPPER - L**

Item no.: 580029  
Pieces per carton 12  
MOQ: Inner box 6



**CAMPING CUTLERY**

Item no.: 580032  
Pieces per carton 10



**TABLE CLOTH SET**

Item no.: 580028  
Size: 180 x 130 cm  
Contents: Table cloth  
including 6 clips  
Pieces per carton 10

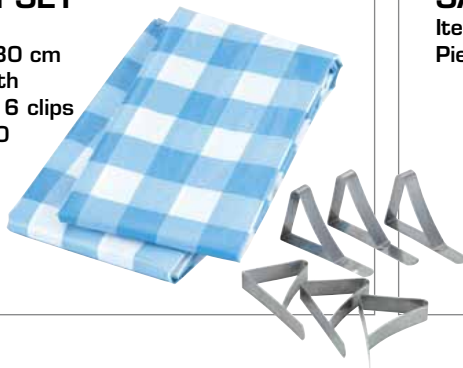

**SALT & PEPPER**

Item no.: 580026  
Pieces per carton 10



**FLEECE BLANKET - MULTI PACK**

Item no.: 520713

Fabric: Fleece

Size: 170 x 130 cm

MOQ: Inner box 4

Pieces per carton 8

**PICNIC RUG**

Item no.: 520712

Fabric: PVC with aluminium finish

Size: 170 x 140 cm

Pieces per carton 6





**CLASSIC LANTERN**

Item no.: 520658  
• U-Tube 5W  
• Rainshield  
• Hanging handle  
• Operates on 4 D-batteries  
• Runtime approx. 20 hours\*  
Pieces per carton 6



**LIGHTHOUSE RECHARGE 230/12V**

Item no.: 520662 / 520663 (UK)  
• Twin U-Tube 13W  
• Rechargeable  
• Supply voltage: 230V cable pack  
• Hanging handle  
• 12V car plug charger included  
• Runtime approx. 5 hours\*  
Pieces per carton 6

**SATELLITE LANTERN - MULTI PACK**

Item no.: 520652  
• Hanging handle  
• 3-functions 3, 6 LED and 3 red flash  
• Magnetic hanging  
• Operates off 3 AAA-batteries  
• Runtime approx. 25 hours\*  
MOQ: Inner box 8  
Pieces per carton 32



**LIGHTHOUSE LANTERN**

Item no.: 520660  
• Twin U-Tube 13W  
• Hanging handle  
• Operates off 8 D-batteries  
• Runtime approx. 10 hours\*  
Pieces per carton 6

**BACKPACK LANTERN**

Item no.: 520656  
• Hanging handle  
• 3-functions 4, 8 LED and flash  
• 8 LED  
• Operates off 4 AA-batteries  
• Runtime approx. 15 hours\*  
Pieces per carton 10



**DREAM LANTERN - MULTI PACK**

Item no.: 520654  
• 4 LED  
• Hanging handle  
• Operates off 3 AA-batteries  
• Runtime approx. 30 hours\*  
MOQ: Inner box 8  
Pieces per carton 16

\* Please note that the indicated runtime depends on quality of batteries used.

**GRIPPER TORCH L**

Item no.: 520651

Pieces per carton 10

- Krypton bulb
- Weatherproof
- Soft touch housing
- Operates off 2 D-batteries
- Runtime approx. 5 hours\*

**MICRO 5 LED HEADLAMP**

Item no.: 500172

Pieces per carton 10

- 5 LED
- Clip for easy hanging
- Detachable headband
- Weatherproof
- Operates off 2 CR2032 (included)

**GRIPPER TORCH M**

Item no.: 520650

Pieces per carton 10

- Krypton bulb
- Weatherproof
- Soft touch housing
- Operates off 2 AA-batteries
- Runtime approx. 5 hours\*



**FOLDING CARRIER 10L**

Item no.: 580122  
 Volume: 10 litre  
 Pack size: 30 x 5 x 5 cm  
 Features: Adjustable tab  
 Convenient carrier handle  
 Small pack size and weight  
 Pieces per carton 10

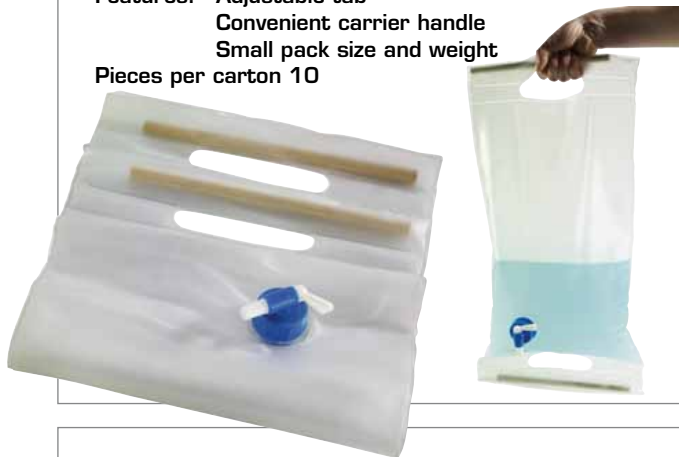
**FOLDING CARRIER 15L**

Item no.: 580123  
 Volume: 15 litre  
 Pack size: 21 x 21 x 10 cm  
 Features: Adjustable tab  
 Convenient carrier handle  
 Small pack size and weight  
 Pieces per carton 10

**JERRY CAN 10 L**

Item no.: 580124  
 Volume: 10 litre  
 Pack size: 30 x 20 x 25 cm  
 Features: Adjustable tab  
 Convenient carrier handle  
 Pieces per carton 4

**JERRY CAN 23L**

Item no.: 580125  
 Volume: 23 litre  
 Pack size: 36 x 24 x 35 cm  
 Features: Adjustable tab  
 Convenient carrier handle 12  
 Pieces per carton 4

**SOLAR SHOWER**

Item no.: 580126  
 Volume: 20 litre  
 Pack size: 17 x 19 x 5 cm  
 Features: Water heating from sun energy  
 Thermometer  
 Convenient carrier/hanging handle  
 Adjustable shower tap  
 Pieces per carton 10

**DUSTPAN AND BRUSH**

Item no.: 580128  
 Pieces per carton 10



**STEEL PEG 19 CM**

Item no.: 580130  
 Size: 19 cm  
 Contents: 10 pcs.  
 Pieces per carton 10

**STEEL PEG 26 CM**

Item no.: 580131  
 Size: 26 cm  
 Contents: 10 pcs.  
 Pieces per carton 10

**PLASTIC PEG**

Item no.: 580132  
 Size: 20 cm  
 Contents: 6 pcs.  
 Pieces per carton 10

**RUBBER/STEEL MALLET**

Item no.: 580134  
 Pieces per carton 10

**PEG REMOVER**

Item no.: 580135  
 Pieces per carton 10

**GROUND SHEET PEG**

Item no.: 580133  
 Size: 8 cm  
 Contents: 6 pcs.  
 Pieces per carton 10

**BELOWS FOOTPUMP**

Item no.: 500165  
 Volume: 3 litre  
 Features: 3 sizes of nozzles included  
 Two functions - inflate/deflate  
 Pieces per carton 10

**BLACK/REFLECTIVE GUYLINES**

Item no.: 580136  
Contents: 4 x 3.5 m  
Pieces per carton 10

**NYLON LINE**

Item no.: 580138  
Contents: 15 m  
Pieces per carton 10

**UTILITY CORD**

Item no.: 580139  
Contents: 20 m  
Pieces per carton 10

**YELLOW GUYLINES**

Item no.: 580137  
Contents: 4 x 4.5 m  
Pieces per carton 10

**CLOTH LINE**

Item no.: 580129  
Contents: 2 m  
Pieces per carton 10



**POLE DIY 9.5 MM**

Item no.: 580140

Contents: 7 sections of 60 cm  
shock cord, pole endings

Pieces per carton 10

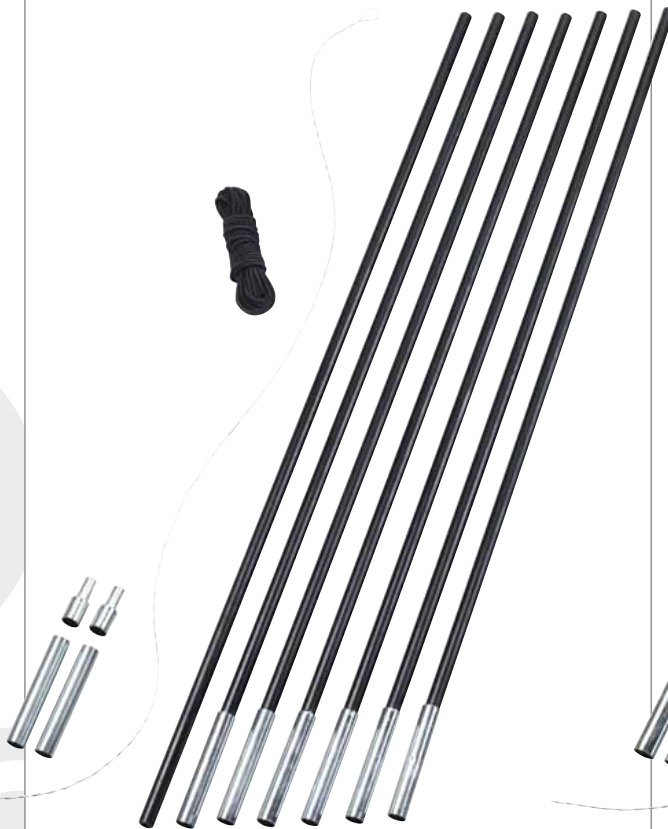
**POLE DIY 11.0 MM**

Item no.: 580141

Contents: 7 sections of 60 cm  
shock cord, pole endings

Pieces per carton 10

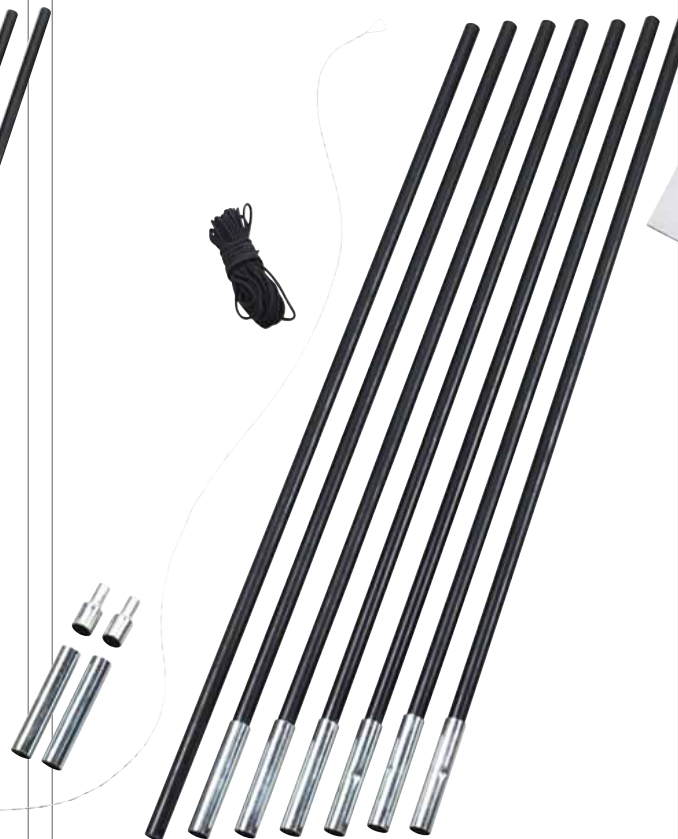
**SHOCK CORD REPAIR SET**

Item no.: 580145

Contents: 15 m

Pieces per carton 10

RANGE

2010



© 2009 Oase Outdoors ApS - Item no.: 9964902



Denmark, Headquarter: Oase Outdoors ApS · Kornvej 9 · DK-7323 Give · easy-camp.com